



**Rantoul Village Board of Trustees**  
**Regular Study Session**  
**July 7, 2026**  
**6:00 PM**

---

*Order of Business*

---

**1. Call to Order**

**2. Roll Call**

**3. Approval of Agenda**

**4. Public Participation**

*Citizens wishing to address the Village Board with respect to any item of business listed on the agenda, or any matter not appearing on the agenda, are asked to sign up on the public participation form, and submit it to the Village Clerk prior to the meeting.*

*Comments will be limited to three minutes for each speaker.*

**5. Items from the Mayor Pro Tempore**

**6. Items from Trustees**

**7. Items from the Clerk**

*All Minutes are draft versions until approved during the Regular Board Meeting. The Village is required to post the approved minutes on the website within ten days of approval.*

(A) Minutes of the June 2, 2026 Board Study Session

(B) Minutes of the June 9, 2026 Board Meeting

(C) Minutes of the June 16, 2026 Special Board Meeting

**8. Items from Human Resources**

(A) Village Applicant Demographics Report

(B) Village Career Opportunities

**9. Items from the Comptroller**

(A) Budget Book

**10. Items from Police Department**

(A) Agreement for the Design Build Contractor for the Public Safety Training Building with Mid Illinois Concrete & Escavation, Inc. in the amount not-to-exceed \$425,000.00

**11. Items from Fire Department**

**12. Items from Airport**

(A) Service Agreement for Consultant Services for Architectural, Engineering, and Planning for the Rantoul National Aviation Center with Hanson Professional Services Inc.

(B) Rantoul National Aviation Center Quarterly Report



**Rantoul Village Board of Trustees**  
**Regular Study Session**  
**July 7, 2026**  
**6:00 PM**

---

*Order of Business*

---

**13. Items from Community Planning & Development**

- (A) Contract for the Construction of the Pleasant Acres Sidewalk Connections Project with A&A Concrete, LLC. in the amount of \$428,855.00

**14. Items from Electric Department**

**15. Items from Parks & Recreation**

**16. Items from Public Works**

- (A) Purchase of Gas Meter Nodes for the Gas Division AMR/AMI Meter Project from Eaton Corporation in the amount of \$40,352.00, with a \$1,000.00 Contingency Fund
- (B) Purchase of a Custom Utility Box for the Gas Division Vehicle from Knapheide Truck Equipment Center in the amount of \$63,876.00, with a \$1,000.00 Contingency Fund
- (C) Purchase of a Trailer-Mounted P2 DuraPatcher for the Street Systems Division from CMW Equipment in the amount of \$102,500.00, with a \$2,500.00 Contingency Fund
- (D) Services Agreement, Change Request #1 for the Line Design Engineering and Support for the Electric Department New Prospect Substation and Feeder Exits Project with BHMG Engineers, Inc. in the amount of \$12,100.00
- (E) Purchase of Express Line Materials for the Electric Department's Proposed New Prospect Substation Project with United Utility Supply in the amount of \$207,596.49, with a \$10,350.00 Contingency Fund
- (F) Service Agreement for the Construction Engineering and Support for the Electric Department's Prospect Substation and Feeder Exits Project with BHMG Engineers, Inc. in the amount not-to-exceed \$400,000.00

**17. Items from the Administrator**

- (A) Ordinance Authorizing a Binding Referendum on the November 3, 2026 Election Ballot asking, "Shall the Village of Rantoul abandon the method of electing Trustees from districts so that Trustees shall be hereafter elected on a Village-wide basis?"
- (B) Resolution Authorizing an Advisory Referendum on the November 3, 2026 Election Ballot asking, "Shall the Village of Rantoul allow Cannabis Establishments to locate and operate within the Village?"
- (C) Notice Regarding the Hap Parker Family Aquatic Center
- (D) Discussion of Parliamentary Procedure: Robert's Rules of Order / Village of Rantoul Rules of Order

**18. Items from Counsel**



**Rantoul Village Board of Trustees**  
**Regular Study Session**  
**July 7, 2026**  
**6:00 PM**

---

*Order of Business*

---

**19. Announcements**

- (A) **Senior Swim - Free!**  
July 10th - 17th - 24th | Noon-1:00pm  
Hap Parker Family Aquatic Center
- (B) **Freedom Fridays Event Series | 6-9:00pm**  
July 10 at the Rantoul Family Sports Complex with the Tom Grassman Band  
July 17 at the Fringe with Vivacious Audio  
July 24 in Downtown Rantoul with 90's Daughter
- (C) **Congresswoman Robin Kelly / IL State Senator Paul Faraci**  
Mobile Office Hours | July 8 1:00-4:00pm  
Rantoul Business Center
- (D) **Former Chanute Air Force Base Public Meeting**  
Update on PFAS Actions & Remedial Investigation  
Wednesday, July 8 at 7:00pm  
Louis B. Schelling Memorial Board Room
- (E) **EAA Young Eagles Rally & Pancake Breakfast - FREE!**  
July 11 | 9:00 - 11:00am  
Rantoul National Aviation Center  
Register at [eaachapters.org](http://eaachapters.org)
- (F) **Senior Luncheon**  
Thursday, July 16 | 11:30am  
Rantoul Recreation Building  
Call 217-893-5703 to RSVP

**20. Items for Closed Session**

- (A) Motion to enter into closed session pursuant to 5 ILCS 120/2 (C) 2, to consider collective negotiating matters between the public body and its employees or their representatives, or deliberations concerning salary schedules for one or more classes of employees
- (B) Motion to enter into closed session pursuant to 5 ILCS 120/2 (C) 1, to consider the appointment, employment, compensation, discipline, performance, or dismissal of specific employees, or legal counsel for the public body, including hearing testimony on a complaint lodged against an employee
- (C) Motion to enter into Closed Session pursuant to 5 ILCS 120/2 (C) 21, for the discussion of Minutes of meetings lawfully Closed under the Open Meetings Act, whether for the purposes of approval by the body of the Minutes or semiannual review of the Minutes as mandated

**21. Adjournment**

**BOARD OF TRUSTEES  
VILLAGE OF RANTOUL**

**AGENDA ITEM**

ITEM: Public Participation	DEPARTMENT:
DATE: July 7, 2026	AMOUNT:
ATTACHMENTS:	ADMINISTRATIVE NOTES:
SUMMARY HIGHLIGHTS:	
RECOMMENDED ACTION:	
DEPARTMENT HEAD APPROVAL	VILLAGE ADMINISTRATOR

**BOARD OF TRUSTEES  
VILLAGE OF RANTOUL**

**AGENDA ITEM**

ITEM: Items from the Clerk	DEPARTMENT:
DATE: July 7, 2026	AMOUNT:
ATTACHMENTS:	ADMINISTRATIVE NOTES:
SUMMARY HIGHLIGHTS:	
RECOMMENDED ACTION:	
DEPARTMENT HEAD APPROVAL	VILLAGE ADMINISTRATOR

**BOARD OF TRUSTEES  
VILLAGE OF RANTOUL**

**AGENDA ITEM**

ITEM: Minutes of the June 2, 2026 Board Study Session	DEPARTMENT: Administration
DATE: July 7, 2026	AMOUNT:
ATTACHMENTS:  1. June 2, 2026 Study Session Minutes - draft	ADMINISTRATIVE NOTES:
SUMMARY HIGHLIGHTS:	
RECOMMENDED ACTION:	
DEPARTMENT HEAD APPROVAL	VILLAGE ADMINISTRATOR

**RANTOUL VILLAGE BOARD OF TRUSTEES  
REGULAR STUDY SESSION  
JUNE 2, 2026**

---

LOUIS B. SCHELLING MEMORIAL BOARD ROOM  
RANTOUL MUNICIPAL BUILDING, 333 S. TANNER, RANTOUL, IL

A Regular Study Session of the Board of Trustees of the Village of Rantoul was held at at 6:00 P.M. Mayor Hall called the proceeding to order.

**Roll Call**

The Clerk called the roll, finding the following members were physically present:

Mayor Hall, Trustees Workman, Crider, Wilson, Graham, Robertson and Haines – 7.

The following representatives of Village departments were also present:

Scott Eisenhauer, Administrator; Chad Smith, Fire Chief; Angela Schultz, Comptroller; Chad Isley, Public Works Director; Chris Milliken; Community Planning and Development; Debbie Sage, Human Resources; Tana Ward, Executive Assistant, Audio/Visual; David Wesner, Attorney; Hank Gamel, Deputy Clerk and Janet Gray, Village Clerk

**Approval of Agenda**

Trustee Robertson moved to approve the agenda. Trustee Workman seconded the motion. On a roll call vote:

YEAS: Robertson, Haines, Workman, Crider, Wilson and Graham – 6.

NAYS: None – 0.

The motion carried 6-0.

**Public Participation**

Mayor Hall opened the public comment portion of the meeting per the Open Meetings Act. No individuals registered with the Village Clerk prior to the meeting.

**Items from the Mayor**

- A. The Mayor expressed condolences to family of the man who had a health problem at the pool. He thanked the life guards who took action right away. He also thanked the Fire Department, EMTs and Police Departments who responded.
- B. The Administrator thanked Mr. Milliken, Mr. Hunt, Ms. Schultz and the Champaign County Treasurer's office. Tomorrow is the last day for the first installment of real estate taxes to be paid. The Village will start issuing rebates next week.
- C. Next week the Mayor will bring forward a name for a Mayor Pro Temp.

**Items from Trustees**

- A. Trustee Robertson asked about updates on the airport. The Administrator said he would provide that information to the Trustees this week and put it online.
- B. Trustee Robertson said he may not be at the June 16 Board Meeting. He does not feel it is the right time to have a transfer station in Rantoul. He does believe they meet the requirements.
- C. Trustee Robertson asked when the Village could purchase the pot hole machine. The Administrator has asked Director Isley to prepare a report of where the money will come from in the Budget.
- D. Trustee Haines asked about the fire and police reports. The Administrator said they would be available at the Board Meeting.
- E. Trustee Haines had asked the Attorney for a copy of outstanding loans in January and still has not received that report. Attorney Wesner said he would get that out this week.

**Items from Clerk**

- A. Minutes of May 5, 2026 Study Session
- B. Minutes of May 12, 2026 Board Meeting

These items will go to the Board for approval.

**Items from Human Resources**

- A. Village Applicant Demographics Report and Career opportunities were listed in the Board Packet.
- B. The Mayor asked what positions were the most difficult to fill. The Human Resources Manager said that the Chief of Operations Waste Water is difficult to fill because of the required certifications and it is hard to find experienced linemen.

**Items from Comptroller**

No items to report.

**Items from Police Department**

- A. The Department requested the approval of an Ordinance Amending Chapter 18, Article II, Section 21 of the Village Code in Connection with the Order of Command and Appointments within the Police Department. This Ordinance would reduce the number of authorized Lieutenant positions to two and create the position of Deputy Chief of Police. This was discussed at the Board's Strategic Planning Session. It will not have an impact on this year's budget.

This item will go to the Board for Approval.

Tony Brown, Chief of Police joined the meeting at 6:24 pm.

**Items from Fire Department**

No items to report.

### **Items from Community Planning and Development**

- A. Chris Milliken, Community Planning and Development, gave an update on the Downtown Reconstruction & Streetscaping Project. They hope to open up Tanner Street next week. The completion date is still the end of June.

### **Items from the Parks and Recreation**

No items to report.

### **Items from Public Works**

- A. The Department requested the approval of an Ordinance authorizing and approving a Loan Agreement from the Water Pollution Control Program in the amount of \$11,000,000. The plant has crucial equipment approaching the end of its reliable service life that needs upgrading. This is for the IEPA Loan, Phase 2.
- B. The Department requested the approval of a Construction Contract for the Electric Department proposed Prospect Substation Project. Bids were received on May 20. The Department is reviewing the two lowest bids and will have a contractor selected by the Board meeting. The two low bids are below the cost projection.
- C. The Department requested the approval of a Service Agreement for the Repair and Rehabilitation of Well 10 at the Water Treatment Plant. They have received quotes from three companies. This will be a complete rebuild. Reserved funds will be used for this project.

These items will go to the Board for approval.

### **Items from Administrator**

The Administrator requested the approval of an Ordinance supplementing and amending Chapter 2, Article III of the Village Code to establish the position of Electric Director. The Administration wishes to establish an Electric Department, thereby separating it from the Public Works Department. To do so, a position for the new Director needs to be created for management and oversight. The Ordinance also outlines the duties and responsibilities of the Director.

This item will go to the Board for approval.

### **Items from Counsel**

Attorney said he would get those loan reports to the Board this week.

### **Announcements**

- A. A Summer Nights Concert Series will be held in Downtown Rantoul on June 5th, 12th, 19th and 26th.
- B. Family Swim Nights will be Wednesday evenings from 7:00-9:00 pm at the Hap Parker Family Aquatic Center. Two free youth admitted with each paid adult.
- C. Kids Foundation of Rantoul is sponsoring Swimming Lessons for Youth ages 3-17 years at the Hap Parker Aquatic Center. Visit the Community Services Center or call 217-893-1530 to apply.

- D. Kids Foundation of Rantoul is sponsoring Forum Fitness Center Membership for Youth ages 14-16 years. This is a one-time, 3-month Membership. Visit the Community Services Center or call 217-893-1530 to apply.
- E. The Freedom Fridays Event Series will be at various locations TBA on July 3rd 10th, 17th and 24th. The July 3rd event will be at the pool with free swimming.
- F. June 9 will be the Hot Rod Power Tour show at the Airport. Vehicles come in around 10:30 am, gates open at 11:00 am.
- G. The 4th of July Parade will be at 9:30 am starting at Maplewood Drive. Register on line. Registration deadline in July 1st at 5:00 pm.
- H. There will be a Special Village Board Meeting on July 16th to discuss and vote on the siting application of the GFL Transfer Station. The Public Record and Findings will be available on the web site. This will be the only item on the agenda.

**Closed Session**

No closed session was held.

**Meeting Adjourned**

The Mayor adjourned the meeting at 6:51 pm.

Respectfully submitted,

Janet E. Gray, MMC  
Village Clerk

**Approved**

---

Samuel E. Hall, III  
Village President

**ATTEST:**

---

Janet E. Gray, MMC  
Village Clerk

I, Janet E. Gray, Village Clerk of the Village of Rantoul, Illinois, do hereby certify that the foregoing minutes are a true and correct copy of the Study Session of the Board of Trustees held June 2, 2026 as the same appears on the records of the Village now in my custody and keeping.

---

Janet E. Gray, MMC  
Village Clerk

**BOARD OF TRUSTEES  
VILLAGE OF RANTOUL**

**AGENDA ITEM**

ITEM: Minutes of the June 9, 2026 Board Meeting	DEPARTMENT: Administration
DATE: July 7, 2026	AMOUNT:
ATTACHMENTS:  1. June 9, 2026 Board Meeting Minutes - draft	ADMINISTRATIVE NOTES:
SUMMARY HIGHLIGHTS:	
RECOMMENDED ACTION:	
DEPARTMENT HEAD APPROVAL	VILLAGE ADMINISTRATOR

**RANTOUL VILLAGE BOARD OF TRUSTEES  
REGULAR BOARD MEETING  
JUNE 9, 2026**

LOUIS B. SCHELLING MEMORIAL BOARD ROOM  
RANTOUL MUNICIPAL BUILDING, 333 S. TANNER, RANTOUL, IL

A Regular Meeting of the Board of Trustees of the Village of Rantoul was held at 6:00 P.M., President Hall presiding. President Hall called the meeting to order.

**Invocation & Pledge of Allegiance**

Rev. Wayne Clevenger of the Rantoul Church of the Nazarene opened the meeting in prayer. Following the invocation, Trustee Wilson led the audience in recitation of the Pledge of Allegiance.

**Roll Call**

The Clerk called the roll, finding the following members were physically present:

Mayor Hall, Trustees Workman, Crider, Wilson, Graham, Robertson and Haines – 7.

The following representatives of Village departments were also present:

Scott Eisenhauer, Administrator; Tony Brown, Police Chief; Angie Schultz, Comptroller; Chad Isley, Public Works Director; Tana Ward Executive Assistant, Audio/Visual; David Wesner, Attorney and Janet Gray, Village Clerk

**Approval of Agenda**

Trustee Robertson moved to approve the agenda for the meeting, as presented. Trustee Wilson seconded the motion. On a Roll Call vote:

YEAS: Robertson, Haines, Workman, Crider, Wilson and Graham – 6.

NAYS: None – 0.

The motion carried 6-0.

**Public Participation**

Mayor Hall opened the public comment portion of the meeting per the Open Meetings Act.

- A. Debbra Sweat addressed the sale of alcohol at the Sports Complex. She stated the Board should reconsider the sale of Marijuana.

## **A. Consent Agenda**

---

### **Approval of Consent Agenda Items by Omnibus Vote**

- A. Appointment of Trustee Regina Crider as Mayor Pro Tempore.
- B. Bills and Monthly Financial Reports.
- C. Minutes of Regular Study Session May 5, 2026.
- D. Minutes of Regular Board Meeting May 12, 2026.

Trustee Graham moved to approve the Consent Agenda items by omnibus vote. Trustee Robertson seconded the motion.

Trustee Haines asked why the Mayor felt the need to name a Mayor Pro Tempore. The Mayor said he thought it was professional and timely to name one.

Trustee Haines asked about the payments from the Village to Rush Softball. The Administrator said it was to pay for the referees.

On a Roll Call vote:

YEAS: Graham, Robertson, Haines, Workman, Crider and Wilson – 6.

NAYS: Haines and Workman – 2.

The motion carried 4-2.

## **B. Consideration of Bids, Contracts & Other Items of Expenditure**

---

Trustee Graham moved to authorize and approve a Construction Contract for the Electric Department's Proposed Prospect Substation Project with LE Myers in the amount of \$4,851,981.12, with a Contingency Fund of \$485,000.00. Trustee Robertson seconded the motion. On a Roll Call vote:

YEAS: Graham, Robertson, Haines, Workman, Crider and Wilson – 6.

NAYS: None – 0.

The motion carried 6-0.

Trustee Graham moved to authorize waiving the Formal Bidding Process, and moved to authorize and approve a Service Agreement for the repair and rehabilitation of Well 10 at the Water Treatment Plant with Municipal Well and Pump in the Amount of \$63,930.00, with a Contingency Fund of \$6,400.00.

Trustee Wilson seconded the motion. On a Roll Call vote:

YEAS: Graham, Robertson, Haines, Workman, Crider and Wilson – 6.

NAYS: None – 0.

The motion carried 6-0.

Trustee Graham moved to authorize and approve a Development Agreement between Village of Rantoul and Maverick Pipe Group, LLC. Trustee Crider seconded the motion. On a Roll Call vote:

YEAS: Graham, Robertson, Haines, Workman, Crider and Wilson – 6.

NAYS: None – 0.

The motion carried 6-0.

Trustee Graham moved to authorize and approve an Intergovernmental Agreement amending the Champaign County Emergency Telephone System Board to include the University of Illinois as a Member. Trustee Haines seconded the motion. On a Roll Call vote:

YEAS: Graham, Robertson, Haines, Workman, Crider and Wilson – 6.

NAYS: None – 0.

The motion carried 6-0.

### **C. Consideration of Ordinances & Resolutions**

---

#### **Ordinance No. 2829**

#### **AN ORDINANCE AMENDING ARTICLE II OF CHAPTER 18 "LAW ENFORCEMENT" OF THE VILLAGE OF RANTOUL CODE IN CONNECTION WITH COMMAND STAFF**

Trustee Graham moved to pass Ordinance No. 2829. Trustee Wilson seconded the motion. On a Roll Call vote:

YEAS: Graham, Robertson, Haines, Workman, Crider and Wilson – 6.

NAYS: None – 0.

The motion carried 6-0.

#### **Ordinance No. 2830**

#### **AN ORDINANCE AMENDING ARTICLE III OF CHAPTER 2 "VILLAGE OFFICERS" OF THE VILLAGE CODE IN CONNECTION WITH ELECTRIC DEPARTMENT DIRECTOR**

Trustee Graham moved to pass Ordinance No. 2830. Trustee Workman seconded the motion. On a Roll Call vote:

YEAS: Graham, Robertson, Haines, Workman, Crider and Wilson – 6.

NAYS: None – 0.

The motion carried 6-0.

#### **Ordinance No. 2831**

#### **AN ORDINANCE AUTHORIZING AND APPROVING A LOAN AGREEMENT FROM THE WATER POLLUTION CONTROL PROGRAM**

Trustee Graham moved to pass Ordinance No. 2831. Trustee Workman seconded the motion. On a Roll Call vote:

YEAS: Graham, Robertson, Haines, Workman, Crider and Wilson – 6.

NAYS: None – 0.

The motion carried 6-0.

**Ordinance No. 2832**

**AN ORDINANCE AUTHORIZING AND APPROVING AN AGREEMENT FOR THE SALE OF REAL ESTATE OWNED BY THE VILLAGE OF RANTOUL, ILLINOIS (909 PACESETTER DRIVE)**

Trustee Graham moved to pass Ordinance No. 2832. Trustee Haines seconded the motion. On a Roll Call vote:

YEAS: Graham, Robertson, Haines, Workman, Crider and Wilson – 6.

NAYS: None – 0.

The motion carried 6-0.

**Resolution No. 6-26-1456**

**A RESOLUTION AUTHORIZING A PROPERTY TAX REIMBURSEMENT PROCEDURE 2025 TAX YEAR**

Trustee Graham moved to pass Resolution No. 6-26-1456. Trustee Robertson seconded the motion. On a Roll Call vote:

YEAS: Graham, Robertson, Haines, Workman, Crider and Wilson – 6.

NAYS: None – 0

The motion carried 6-0.

**D. Other Business**

---

- A. Trustee Crider asked if the Village could print a Community Newsletter that would go out in the Utility bills.
- B. Trustee Crider said a resident asked if the Village had a tree removal program for seniors. The Village does not. The Administrator suggested looking at other grant programs.
- C. The monthly Police Department Report was provided to the Board.
- D. The monthly Fire Department Report was provided to the Board.

**E. Public Announcements**

---

- A. The Hot Rod Power Tour was in town today with over 600 vehicles, The Mayor thanked the Organizer and Village Staff for making this event a success.
- B. Seniors Swim for Free from Noon – 1:00 pm on June 12th, 19th, and 26th at the Hap Parker Family Aquatic Center. Citizens must be 55 or older.
- C. A Summer Nights Concert Series will be held in Downtown Rantoul from 6:00 – 9:00 pm on June 12th, 19th and 26th. Candy Foster is singing on the 12th.
- D. The Rantoul Rotary Pancake & Sausage Breakfast Saturday will be July 4 from at 7:00 -11:00 am at the Rantoul Township High School Cafetorium.
- E. The Freedom Fridays Event Series will be on July 3rd,10th,17th and 24th at locations TBA.
- F. Freedom Celebration Fireworks will be Friday, July 3rd at Dusk at the Rantoul National Aviation Center Airport.

- G. The Independence Day Parade will be Saturday, July 4th at 9:30 am starting at Maplewood Drive.
- H. Former Chanute Air Force Base Public Meeting Update on PFAS Actions & Remedial Investigation will be Wednesday, July 8th at 7:00 pm in the Louis B. Schelling Memorial Board Room.
- I. There will be a Special Board Meeting next Tuesday the 16th in the Board Room to discuss approving the siting of the GFL Transfer Station requested by Area Disposal.

**F. Closed Session**

---

No Closed session was held.

**G. Adjournment**

---

There being no further business to come before the Board, Trustee Crider moved to adjourn the meeting. Trustee Robertson seconded the motion. On a Roll Call vote:

YEAS: Crider, Wilson, Graham, Robertson, Haines and Workman – 6.

NAYS: None – 0.

The motion carried 6-0.

MEETING ADJOURNED AT 6:40 PM.

Janet E. Gray, MMC  
Village Clerk

**Approved**

---

Samuel E. Hall, III  
Village President

**ATTEST:**

---

Janet E. Gray, MMC  
Village Clerk

I, Janet E. Gray, Village Clerk of the Village of Rantoul, Illinois, do hereby certify that the foregoing minutes are a true and correct copy of the Regular Meeting of the Board of Trustees held June 9, 2026 as the same appears on the records of the Village now in my custody and keeping.

---

Janet E. Gray, MMC  
Village Clerk

**BOARD OF TRUSTEES  
VILLAGE OF RANTOUL**

**AGENDA ITEM**

<p>ITEM: Minutes of the June 16, 2026 Special Board Meeting</p>	<p>DEPARTMENT: Administration</p>
<p>DATE: July 7, 2026</p>	<p>AMOUNT:</p>
<p>ATTACHMENTS:</p> <p>1. June 16, 2026 Special Board Meeting Minutes - draft</p>	<p>ADMINISTRATIVE NOTES:</p>
<p>SUMMARY HIGHLIGHTS:</p>	
<p>RECOMMENDED ACTION:</p>	
<p>DEPARTMENT HEAD APPROVAL</p>	<p>VILLAGE ADMINISTRATOR</p>

**RANTOUL VILLAGE BOARD OF TRUSTEES  
SPECIAL BOARD MEETING  
June 16, 2026**

---

LOUIS B. SCHELLING MEMORIAL BOARD ROOM  
RANTOUL MUNICIPAL BUILDING, 333 S. TANNER, RANTOUL, IL

A Special Meeting of the Board of Trustees of the Village of Rantoul was held at 6:00 pm. President Hall presiding. President Hall called the meeting to order.

**Roll Call**

The Clerk called the roll, finding the following members present:

Mayor Smith, Trustees Workman, Crider, Wilson, Graham, Robertson and Haines – 7.

The following representatives of Village departments were also present:

Scott Eisenhauer, Administrator; Bob Coverdill, Airport Manager; Tana Ward, Executive Assistant, Audio/Visual; David Wesner, Attorney; Hank Gamel, Deputy Clerk and Janet Gray, Village Clerk.

**Approval of the Agenda**

Trustee Graham moved to approve the agenda for the meeting as presented. Trustee Crider seconded the motion. On a Roll Call vote:

YEAS: Graham, Robertson, Haines, Workman, Crider and Wilson – 6.

NAYS: None – 0.

Motion Approved 6-0.

**Public Participation**

Mayor Hall opened the public comment portion of the meeting per the Open Meetings Act.

- Lori Shields, 350 W. Champaign, stated she is against the Transfer Station, particularly at the proposed location.
- Rick Shields, General Manger Shields Sales, said he is concerned about Real Estate values, odors and truck traffic. He is against the location.
- Randy McKaufsky represents Westland Meadows Homeowners Association. They are concerned about the location, odor and rodents. They do not believe GFL adequately answered all the questions regarding the issues.
- Janaki Nair, attorney for Area Disposal reviewed the application process. In June 2025 an agreement was approved, the application was filed December 7, the public hearing held on April 17 and the record closed May 18. She believes that they have proved that Area Disposal Services met the siting requirements.
- Chris Kaler said he felt traffic would be busier. He does not see any reward for Rantoul for having the Transfer Station; only risk at this location.

- Art Hess restated that he thinks the Village has nothing to gain with the Transfer Station – only Area Disposal will gain. He is concerned with property values, heavy traffic and zoning.
- Kenda Hess thanked the community for supporting their business. She is concerned about blowing trash.

**Discussion of Area Disposal Service Proposed Transfer Station**

- Trustee Graham said he thought the Village should approve the Ordinance with conditions.
- Trustee Robertson thinks the facility should be in a different location. If Area Disposal can't pick up garbage effectively how can they properly run a Transfer Station.
- Trustee Haines agrees that the location should be somewhere else; perhaps on the former Air Force Base.

**Consideration of Ordinances & Resolution**

Trustee Workman moved to authorize and approve with conditions the Area Disposal Service, Inc. Siting Application for the proposed Rantoul Recycling and Transfer Station located Northeast of Interstate 57 and West Champaign Ave. The Application was filed, and the testimony and evidence concerning the Application, has established that the proposed Facility satisfies all the criteria for local siting approval set forth in Section 39.2 of the Environmental Protection Act (415 ILCS 5) and Chapter 28, Article IV of the Rantoul Village Code. Trustee Graham seconded the motion. On a Roll Call vote:

YEAS: Workman, Crider, Graham, and Mayor Hall – 4.

NAYS: Wilson, Robertson and Haines - 3

Motion carried 4-3.

**Public Announcements**

- A Summer Nights Concert Series will be held in Downtown Rantoul from 6:00 – 9:00 pm on June 19th and 26th.
- The Rantoul Rotary Pancake & Sausage Breakfast Saturday will be July 4th from at 7:00 -11:00 am at the Rantoul Township High School Cafetorium.
- The Freedom Fridays Event Series will be on July 3rd 10th, 17th and 24th at locations TBA.
- Freedom Celebration Fireworks will be Friday, July 3rd at Dusk at the Rantoul National Aviation Center Airport.
- The Independence Day Parade will be Saturday, July 4th at 9:30 am starting at Maplewood Dr.
- Former Chanute Air Force Base Public Meeting Update on PFAS Actions & Remedial Investigation will be Wednesday, July 8th at 7:00 pm in the Louis B. Schelling Memorial Board Room.

**Adjournment**

There being no further business to come before the Board, Trustee Crider moved to adjourn the meeting. Trustee Robertson seconded the motion. On a Roll Call vote:

YEAS: Crider, Wilson, Graham, Robertson, Haines and Workman - 6.

NAYS: None – 0.

The motion carried 6-0.

The meeting was adjourned at 7:06 pm.

Janet E. Gray, MMC  
Village Clerk

**Approved**

---

Samuel E Hall, III  
Village President

**ATTEST:**

---

Janet E. Gray, MMC  
Village Clerk

I, Janet E. Gray, Village Clerk of the Village of Rantoul, Illinois, do hereby certify that the foregoing minutes are a true and correct copy of the Regular Meeting of the Board of Trustees held June 16, 2026 as the same appears on the records of the Village now in my custody and keeping.

---

Janet E. Gray, MMC  
Village Clerk

**BOARD OF TRUSTEES  
VILLAGE OF RANTOUL**

**AGENDA ITEM**

ITEM: Village Applicant Demographics Report	DEPARTMENT: Administration
DATE: July 7, 2026	AMOUNT:
ATTACHMENTS:  1. HR Report - June 2026	ADMINISTRATIVE NOTES:
SUMMARY HIGHLIGHTS:	
RECOMMENDED ACTION:	
DEPARTMENT HEAD APPROVAL Debbie Sage	VILLAGE ADMINISTRATOR Scott Eisenhauer

# Open Positions for Village of Rantoul

June 2026

Position					
	Census Report 2021	Police Officer		Experienced Police Officer	
Race		Number	Percentage	Number	Percentage
White	61.5%	23	72%	1	100%
African American	19.6%	6	19%	0	0%
Asian	1.6%	0	0%	0	0%
Native Hawaiian/Pacific Islander	0.0%	0	0%	0	0%
Hispanic/Latino	12.7%	0	0%	0	0%
American Indian	0.3%	0	0%	0	0%
Two or More Races	16.2%	1	3%	0	0%
Unknown	0.0%	2	6%	0	0%
Gender					
Male	46.8%	24	75%	1	100%
Female	53.2%	7	22%	0	0%
Unknown	0.0%	1	3%	0	0%
Total Applications					
Population Estimate, 07/01/2021	12,119	32		1	
Open / Filled					
		Full Time Position		Full Time Position	
		Police		Police	

Position					
	Census Report 2021	Director of Electric		Chief of Operations - Wastewater	
Race		Number	Percentage	Number	Percentage
White	61.5%	2	100%	4	17%
African American	19.6%	0	0%	2	8%
Asian	1.6%	0	0%	0	0%
Native Hawaiian/Pacific Islander	0.0%	0	0%	0	0%
Hispanic/Latino	12.7%	0	0%	0	0%
American Indian	0.3%	0	0%	0	0%
Two or More Races	16.2%	0	0%	0	0%
Unknown	0.0%	0	0%	18	75%
Gender					
Male	46.8%	2	100%	6	25%
Female	53.2%	0	0%	0	0%
Unknown	0.0%	0	0%	18	75%
Total Applications					
Population Estimate, 07/01/2021	12,119	2		24	
Open / Filled					
		Full Time Position		Full Time Position	
		Electric		Public Works	

# Open Positions for Village of Rantoul

June 2026

Position					
	Census Report 2021	Property Maint. & Housing Inspector		Street & Systems Operator	
<b>Race</b>					
White	61.5%	8	61%	14	73%
African American	19.6%	3	23%	3	16%
Asian	1.6%	0	0%	0	0%
Native Hawaiian/Pacific Islander	0.0%	0	0%	0	0%
Hispanic/Latino	12.7%	1	8%	0	0%
American Indian	0.3%	0	0%	0	0%
Two or More Races	16.2%	0	0%	2	11%
Unknown	0.0%	1	8%	0	0%
<b>Gender</b>					
Male	46.8%	8	62%	18	95%
Female	53.2%	5	38%	1	5%
Unknown	0.0%	0	0%	0	0%
<b>Total Applications</b>					
Population Estimate, 07/01/2021	12,119	13		19	
<b>Open / Filled</b>					
		Full Time Position		Full Time Position	
		Community Planning		Public Works	

Position					
	Census Report 2021	Lineman		Administrative Assistant	
<b>Race</b>					
White	61.5%	2	67%	15	75%
African American	19.6%	1	33%	1	5%
Asian	1.6%	0	0%	0	0%
Native Hawaiian/Pacific Islander	0.0%	0	0%	0	0%
Hispanic/Latino	12.7%	0	0%	4	20%
American Indian	0.3%	0	0%	0	0%
Two or More Races	16.2%	0	0%	0	0%
Unknown	0.0%	0	0%	0	0%
<b>Gender</b>					
Male	46.8%	3	100%	2	10%
Female	53.2%	0	0%	16	80%
Unknown	0.0%	0	0%	2	10%
<b>Total Applications</b>					
Population Estimate, 07/01/2021	12,119	3		20	
<b>Open / Filled</b>					
		Full Time Position		Full Time Position	
		Electric		Community Planning	

# Open Positions for Village of Rantoul

June 2026

Position					
	Census Report 2021	Evidence Custodian		Firefighter	
<b>Race</b>					
White	61.5%	1	100%	2	33%
African American	19.6%	0	0%	2	33%
Asian	1.6%	0	0%	0	0%
Native Hawaiian/Pacific Islander	0.0%	0	0%	0	0%
Hispanic/Latino	12.7%	0	0%	1	17%
American Indian	0.3%	0	0%	0	0%
Two or More Races	16.2%	0	0%	1	17%
Unknown	0.0%	0	0%	0	0%
<b>Gender</b>					
Male	46.8%	1	100%	5	83%
Female	53.2%	0	0%	1	17%
Unknown	0.0%	0	0%	0	0%
<b>Total Applications</b>					
Population Estimate, 07/01/2021	12,119	1		6	
<b>Open / Filled</b>					
		Part Time		Part Time	
		Police		Fire	

# Open Positions for Village of Rantoul

June 2026

Position					
	Census Report 2021	Total Applicants		New Hires / Rehires June 2026	
<b>Race</b>					
White	61.5%	72	60%	3	75%
African American	19.6%	18	15%	0	0%
Asian	1.6%	0	0%	0	0%
Native Hawaiian/Pacific Islander	0.0%	0	0%	0	0%
Hispanic/Latino	12.7%	6	5%	1	25%
American Indian	0.3%	0	0%	0	0%
Two or More Races	16.2%	4	3%	0	0%
Unknown	0.0%	21	17%	0	0%
<b>Gender</b>					
Male	46.8%	70	58%	1	25%
Female	53.2%	30	25%	3	75%
Unknown	0.0%	21	17%	0	0%
<b>Total Applications</b>					
Population Estimate, 07/01/2021	12,119	121		4	
<b>Open / Filled</b>					
		Application Totals		New Hires / Rehires	

## How did the applicant find out about the open position?

Indeed	38
Blank	20
Village of Rantoul Employee	18
Other	13
Friend	11
FaceBook	9
Relative	2

**BOARD OF TRUSTEES  
VILLAGE OF RANTOUL**

**AGENDA ITEM**

ITEM: Village Career Opportunities	DEPARTMENT: Administration
DATE: July 7, 2026	AMOUNT:
ATTACHMENTS:  1. Now Hiring 2. Career Opportunities	ADMINISTRATIVE NOTES:
SUMMARY HIGHLIGHTS:	
RECOMMENDED ACTION:	
DEPARTMENT HEAD APPROVAL Debbie Sage	VILLAGE ADMINISTRATOR Scott Eisenhauer



— THE VILLAGE OF RANTOUL —  
**IS NOW  
HIRING!**

**JOIN OUR TEAM. MAKE A DIFFERENCE.**

-  **ADMINISTRATIVE ASSISTANT**
-  **INSPECTOR**
-  **POLICE OFFICER**
-  **FIREFIGHTER**
-  **STREET & SYSTEM OPERATOR**

 **APPLY ONLINE TODAY!**  
[www.myrantoul.com/jobs](http://www.myrantoul.com/jobs) 

 TEAMWORK |  INTEGRITY |  SERVICE |  COMMUNITY

# NOW HIRING!

★  
**BUILD YOUR FUTURE.**

*Build Our Community.*



MAKE A DIFFERENCE IN THE PLACE WE ALL CALL HOME.



**MEANINGFUL  
WORK**



**COMPETITIVE  
BENEFITS**



**PAID TIME  
OFF**



**GROWTH  
OPPORTUNITIES**



**STRONG  
COMMUNITY**

★ **JOIN OUR TEAM!** ★

View open positions and apply today at:

[www.myrantoul.com/jobs](http://www.myrantoul.com/jobs)



↑ **SCAN ME!**



The Village of Rantoul is an Equal Opportunity Employer.

**BOARD OF TRUSTEES  
VILLAGE OF RANTOUL**

**AGENDA ITEM**

ITEM: Budget Book	DEPARTMENT: Administration
DATE: July 7, 2026	AMOUNT:
ATTACHMENTS:	ADMINISTRATIVE NOTES:
SUMMARY HIGHLIGHTS: The Fiscal Year 2027 Budget Book can be viewed at <a href="#">this link</a> .	
RECOMMENDED ACTION:	
DEPARTMENT HEAD APPROVAL Angela Schultz	VILLAGE ADMINISTRATOR Scott Eisenhauer

**BOARD OF TRUSTEES  
VILLAGE OF RANTOUL**

**AGENDA ITEM**

<p>ITEM: Agreement for the Design Build Contractor for the Public Safety Training Building with Mid Illinois Concrete &amp; Excavation, Inc. in the amount not-to-exceed \$425,000.00</p>	<p>DEPARTMENT: Police Department</p>
<p>DATE: July 7, 2026</p>	<p>AMOUNT: Not-to-Exceed \$425,000.00</p>
<p>ATTACHMENTS:</p> <ol style="list-style-type: none"> <li>1. Mid Illinois Public Safety Training Building Proposal</li> <li>2. Public Safety Training Building Drawing</li> </ol>	<p>ADMINISTRATIVE NOTES:</p>
<p><b>SUMMARY HIGHLIGHTS:</b>  This agenda item provides for a contract with Mid Illinois Concrete &amp; Excavation, Inc. for construction of the Public Safety Training Building. The Rantoul Police Department sought proposals for the design and construction of the Public Safety Training Building. Two proposals were received, which were reviewed by Village staff.</p> <p>Mid Illinois Concrete &amp; Excavation, Inc. provided a proposal that met the requirements, and it had the lowest responsive quote. With your approval, we will award the contract to Mid Illinois Concrete &amp; Excavation, Inc. for the construction of the Public Safety Training Building to be completed before December 31, 2026. This project is paid for by a grant provided by the State of Illinois, utilizing the remaining ARPA (America Rescue Plan Act) funds, contributions from outside law enforcement agencies, and a donation by the Rantoul Police Community Support Association.</p>	
<p><b>RECOMMENDED ACTION:</b> Authorize the Agreement for the Design Build Contractor for the Public Safety Training Building with Mid Illinois Concrete &amp; Excavation, Inc. in the amount not-to-exceed \$425,000.00</p>	
<p>DEPARTMENT HEAD APPROVAL Chief Tony Brown</p>	<p>VILLAGE ADMINISTRATOR Scott Eisenhauer</p>



# Proposal

---

**Rantoul Police Department**  
**Attn: Tony Brown**  
**109 E Grove Ave.**  
**Rantoul, IL 61866**

**Job: Rantoul Municipal Education Training Center for Advanced Development**  
**Location: Rantoul, IL**

---

Mid Illinois Concrete proposes to complete the following scope of work as outlined below.

---

## Scope of Work:

- **Concrete: \$62,310.00**
  - Grading and site work is not included. Building pad to be provided by others.
  - Furnish and install rebar reinforcing.
  - Excavate and bank pour 16"x36" grade beam foundations.
  - Form and pour a 6"x6" rat wall for exterior walls to bear on.
  - Furnish, place, and compact up to 4" of CA-6 for slab sub-base.
  - Furnish and install under slab vapor barrier.
  - Furnish, place, and trowel finish 4" concrete slab on grade reinforced with wire mesh.
  - Provide control joints and apply curing compound.
  - Furnish and install concrete sealer for finished floors.
  - Furnish and install SL-1 over expansion joints.
  - Excavate down to -3' outside exterior doors and backfill with frost free rock.
  - Furnish, place, and broom finish 6" concrete stoops.
  - Clean up our work.
  
- **Rough Carpentry/Interior Finishes: \$237,200.00**
  - Furnish and install 2x6 exterior wall framing at 24" O.C.
  - Furnish and install 2x4 interior wall framing at 24" O.C.
  - Furnish and install roof trusses at 24" O.C.
  - Furnish and install plywood roof and wall sheathing.
  - Furnish and install metal fascia and soffits.
  - Furnish and install house wrap.
  - Furnish and install metal roof and wall sheathing.
  - Furnish and install inwall and roof insulation.
  - Furnish and install gypsum board on walls and ceilings.
    - Ammo room to receive 4-layers of drywall for a 2hr rated room.
  - Furnish and install expanded metal sheathing inside of Storage Room wall construction.

---

Ph: 217.366.3444  
Fax: 217.954.1601

P.O. Box 926, Champaign, IL 61824-0926



# Proposal

---

- Furnish and install hollow metal doors, frames, and hardware.
  - Furnish and install windows.
  - Furnish and install restroom accessories.
  - Furnish and install casework and top.
  - Tape and finish drywall.
  - Prime and paint drywall with 2 coats of paint.
  - Paint doors, frames, and windows.
- **Electrical: \$22,865.00**
    - Provide and install a new 200-amp service on the building with a 42 circuit main breaker panel.
    - Provide and install one (1) each AE110 fan in the bathroom and vent to the outside
    - Provide and install wiring for an electric hot water heater, an air conditioner and an air compressor
    - Provide and install wiring for the furnace
    - Provide and install outlets and switches and lighting.
      - The inside lighting fixtures are to be 2'x4' LED flat panel surface mount and color selectable
    - Provide and install three (3) each wall packs ~ one (1) by each door to be controlled by a switch and a photo cell.
    - **Power company to provide power to the building. Bringing power to the building is not included.**
  - **Mechanical: \$45,970.00**
    - Provide bathroom exhaust for each restroom. Vented to exterior.
    - Provide stand alone electric wall heater in Range Storage.
    - Provide 5T air conditioner with 15KW electric heat strip.
    - Furnish and install electric furnace with matched A/C unit.
    - Furnish ductwork below joist space.
    - Add fire dampers for ammo room.
  - **Plumbing: \$36,900.00**
    - Provide sanitary from foundation to fixtures.
    - Provide an electric water heater to serve lavs and sinks.
    - Provide water from foundation to fixtures.
    - Provide sink complete with pull-out faucet.
    - Provide ADA water closet and ADA lavatory in each restroom (manual, flushtank)
    - Floor drains in each restroom and mechanical room.

**Total Base Bid: \$405,245.00**

---

Ph: 217.366.3444  
Fax: 217.954.1601

P.O. Box 926, Champaign, IL 61824-0926



## Proposal

---

- **Deductive Alternate: Remove Gyp. Board From ceiling and Walls in Storage: (\$9,500.00)**
  - Deduct gyp wall board on 4 sides of storage.
  - Deduct gyp ceiling board in storage.
  - Deduct tape and paint in storage.
  - Walls and ceilings to be exposed studs and insulation.

### Exclusions / Clarifications:

- **Pricing is for budgetary purposes only.**
- **Mid Illinois Concrete & Excavation is a Veteran Owned Business.**
- **Engineered drawings are not included.**
- **Testing, permits, fees and bonds are not included.**
- Construction layout and engineering is not included.
- Locating of private utilities and under slab utilities is by provided by others. Mid-Illinois Concrete is not responsible for any damage, delays or associated cost due to unmarked private utilities.
- **Taxes are not included.**
- **Temporary protection or enclosures are not included.**
- **Furnishing or installing of water line is not included as not enough detail is provided at this time.**
- **Electric power to be brought to the building by others.**
- **Grading and site work is not included. Building pad to be provided by others.**
- **Concrete parking lots and sidewalks are not included.**
- **Site gravel is not included.**
- Snow or ice removal is not included.
- Dumpsters are not included. Dumpsters to be provided by others for demo and job disposal.
- Furnishing of misc. metals, anchor bolts, base plates, bollards, handrails, etc. are not included.
- No back charge to Mid-Illinois Concrete will be recognized without 48hr written notice.
- This proposal, including terms and conditions, if accepted will become part of any contract document.
- This proposal is good for 30 days.

Thank you for the opportunity to quote this project. Please feel free to contact me if you have any questions or concerns.

Mid Illinois Concrete & Excavation, Inc.

*Ryan Spencer*

Ryan Spencer

---

Ph: 217.366.3444  
Fax: 217.954.1601

P.O. Box 926, Champaign, IL 61824-0926



# Proposal

---

**ACCEPTANCE OF PROPOSAL**

The above prices, specifications and conditions are satisfactory and are hereby accepted. You are authorized to do the work as listed as above. Payments will be made upon receipt of invoice unless other arrangements are made.

Authorized Signature: \_\_\_\_\_

Date of Acceptance: \_\_\_\_\_

---

Ph: 217.366.3444  
Fax: 217.954.1601

P.O. Box 926, Champaign, IL 61824-0926

$\frac{1}{8}'' = 1'$

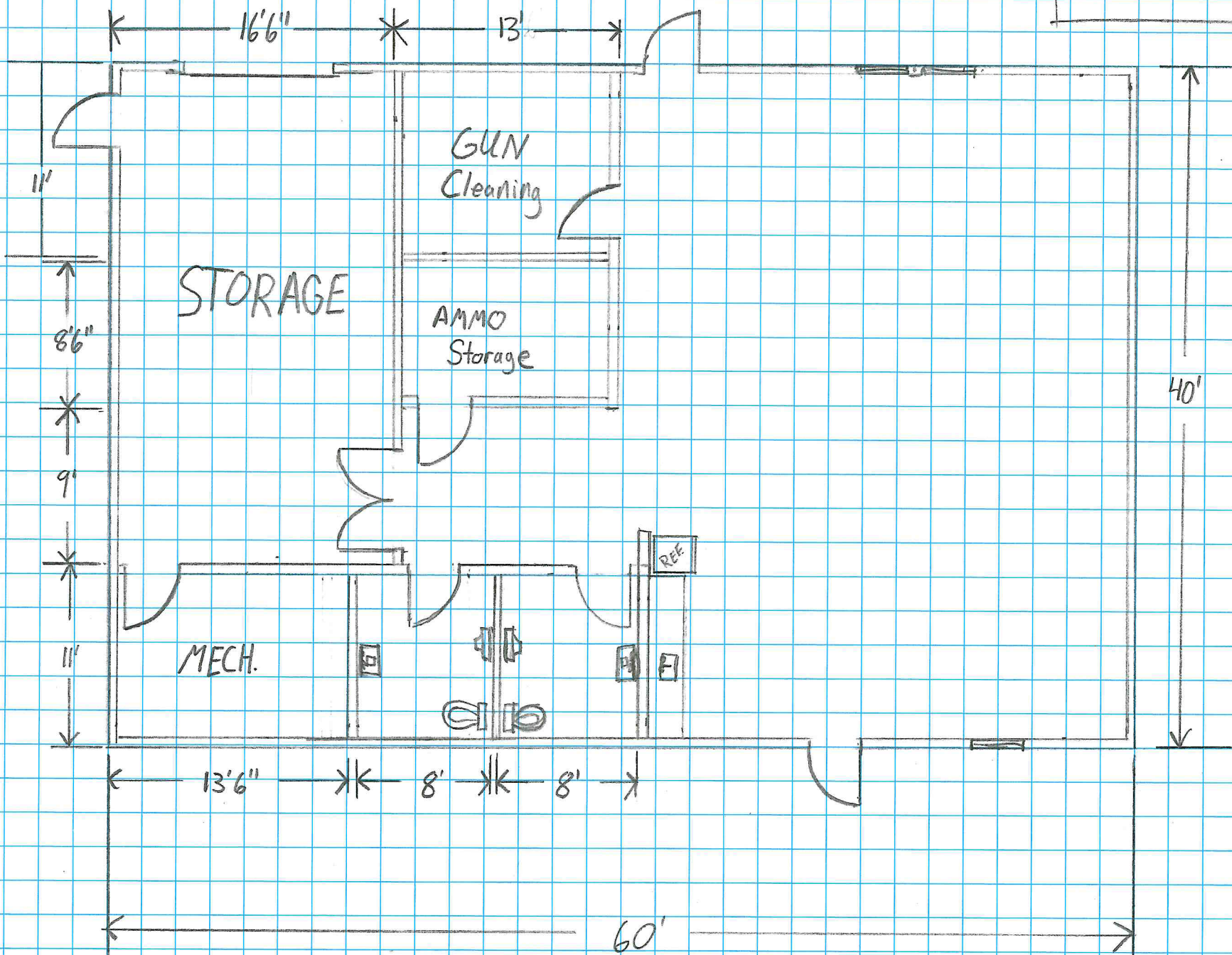

**BOARD OF TRUSTEES  
VILLAGE OF RANTOUL**

**AGENDA ITEM**

ITEM: Items from Airport	DEPARTMENT: Administration
DATE: July 7, 2026	AMOUNT:
ATTACHMENTS:	ADMINISTRATIVE NOTES:
SUMMARY HIGHLIGHTS:	
RECOMMENDED ACTION:	
DEPARTMENT HEAD APPROVAL	VILLAGE ADMINISTRATOR

**BOARD OF TRUSTEES  
VILLAGE OF RANTOUL**

**AGENDA ITEM**

<p>ITEM: Service Agreement for Consultant Services for Architectural, Engineering, and Planning for the Rantoul National Aviation Center with Hanson Professional Services Inc.</p>	<p>DEPARTMENT: Administration</p>
<p>DATE: July 7, 2026</p>	<p>AMOUNT:</p>
<p>ATTACHMENTS:  1. Hanson - Statement of Qualifications</p>	<p>ADMINISTRATIVE NOTES:</p>
<p>SUMMARY HIGHLIGHTS:</p>	
<p>RECOMMENDED ACTION:</p>	
<p>DEPARTMENT HEAD APPROVAL Bob Coverdill</p>	<p>VILLAGE ADMINISTRATOR Scott Eisenhauer</p>

RFQ# VRNTL-27-Q-01

# AIRPORT ENGINEERING & PLANNING SERVICES

STATEMENT OF QUALIFICATIONS  
VILLAGE OF RANTOUL, IL

JUNE 25, 2026



June 25, 2026

Rantoul National Aviation Center  
ATTN: Bob Coverdill  
333 S. Tanner St.  
Rantoul, IL 61866**RE: Request for Qualifications - Engineering and Planning Services**

Mayor Hall, Trustees, Administrator Eisenhower, Director Isley, Manager Milliken, and Airport Manager Coverdill:

As the Village evaluates consultants submitting qualifications to provide engineering services to the Rantoul National Aviation Center (RNAC), traits such as professional and technical experience and competency, responsiveness, and a project team with a strong commitment to successful projects will naturally be required of the selected consultant.

**Hanson Professional Services Inc. (Hanson)** possesses these attributes, the respect of our industry peers, the appreciation of our clients, and the project experience necessary to successfully meet the expectations of the Village of Rantoul. Our airport consulting resume is extensive, with more than four decades of experience with general aviation airport clients – facilities just like RNAC.

Hanson is an employee-owned multidisciplinary firm founded in 1954, with more than 65 aviation-dedicated professionals and more than 600 employees firm-wide. Our office geography allows for routine face-to-face access with IDOT-Aeronautics being headquartered in Springfield, with aviation support staff in Peoria, St. Louis/St. Charles, Marion, and Lisle, IL. Hanson has the depth, experience, and relationships to respond to any task demanded of us within this contract, and remains IDOT-prequalified in all phases of airport improvement projects.

We offer the airport several **key elements that differentiate us from the other firms** in the state, in addition to our technical knowledge and relevant project experience. A partnership with Hanson would also include:

- A partner for the **Military Airport Program (MAP)**. Through many years of advocacy to State and FAA officials, assistance with gathering support, presenting Rantoul's infrastructure needs at conferences, and the preparation and application into the MAP program, Hanson possesses a deep understanding of Rantoul's designation into the program and is excited and ready with a plan to enter into these transformative next several years of projects.
- An experienced **Project Manager, Jeff Olson, PE**, with an institutional knowledge of the Rantoul National Aviation Center. Jeff provides a continuity to the airport to continue to advance airport improvement projects and improve the airfield infrastructure. He has the personality to interact well with not only the Airport but also with IDOT-Aeronautics and the FAA to make sure Rantoul stays well positioned within the state aviation system. In addition to Jeff's last fifteen years working with Airport clients in Illinois, he serves as Hanson's airport discipline manager and the Illinois Public Airport Association's consultant advisor.
- **In-house expertise for specialty services**, including airport environmental assessments and airport land acquisition, airfield electrical engineering, water resources, geotechnical engineering, and surveying. Value-adds such as use of drone technology for wildlife monitoring and obstruction assessments have helped reduced our clients' costs. Having these services in-house helps our projects run smoother, more efficiently and more cost effectively.
- Aviation engineers and other services based out of our central Illinois based offices, allowing us to be **available for meetings and site visits**.

We encourage you to contact our references to review their experiences working with Hanson. Our employee-owners take great pride and work hard to exemplify our collaborative culture, and we believe you will hear that echoed by our clients. Hanson is excited about the potential to continue to provide engineering services to the Village of Rantoul! If you need more information or would like to schedule a meeting, please do not hesitate to contact me at 217-473-6907 or by e-mail at [jolson@hanson-inc.com](mailto:jolson@hanson-inc.com).

Sincerely,

**Hanson Professional Services Inc.**Jeff Olson, PE  
Aviation Discipline Manager

**QUALIFICATIONS AND PREVIOUS EXPERIENCE**

Below is a sampling of Hanson’s similar airport experience.

**Recent Projects**

- Rantoul National Aviation Center, Rehabilitate Runway 18/36, Rantoul, IL
- Rantoul National Aviation Center, Rehabilitate Runway 9/27, Rantoul, IL
- Effingham County Regional Airport, Extend Runway 11/29 and Taxiway to 6,000 Feet, Effingham, IL
- Crawford County Airport, Construct New Terminal, Robinson, IL
- Crawford County Airport, Construct Parallel Taxiway to Runway 9/27, Robinson, IL
- Rehabilitate Runway 13/31 and Remark Airfield, Jacksonville Municipal Airport, Jacksonville, IL
- Update Airport Master Plan, Jacksonville Municipal Airport, Jacksonville, IL
- Construct Partial Parallel Taxiway to Runway 22, Jacksonville Municipal Airport, Jacksonville, IL
- Construct Parallel Taxiway to Runway 9/27, Crawford County Airport, Robinson, IL
- Rehabilitate Runway 18/36, Ingersoll Airport, Canton, IL



**Crawford County Airport - New Terminal**



**Effingham County Regional Airport - Runway 11/29 Extension**



**Jacksonville Municipal Airport - Rehabilitate Runway 13/31 and Remark Airfield**

**SIMILAR PROJECT EXPERIENCE WITH REFERENCES**

**CRAWFORD COUNTY AIRPORT, ROBINSON, IL**

Dave Shaw, Chairman, 618-544-4653

- Airport Master Plan
- ALP Phase 2 - Terminal Area Plan
- Terminal Building

**JACKSONVILLE MUNICIPAL AIRPORT**

Shastin Saxer, Airport Manager, 217-243-5824

- Rehabilitate Runway 13/31 and Remark Airfield
- Update Airport Master Plan
- Construct Partial Parallel Taxiway to Runway 22

**EFFINGHAM COUNTY REGIONAL AIRPORT, EFFINGHAM, IL**

Greg Koester, Airport Superintendent, 217-342-8400

- Extend Runway 11/29 and Taxiway to 6,000 Feet
- Construct Hangar
- Expand Terminal Aircraft Parking Ramp

**GALESBURG MUNICIPAL AIRPORT**

Aaron Gavin, Director of Public Works, 309-345-3624

- Rehabilitate Runway 3/21
- Airport Layout Plan and Narrative Report
- Rehabilitate Auto Parking Lots and Access Road

**JEFF OLSON, PE**

Project Manager

Jeff is the firm's Aviation Discipline Manager, supervising aviation design and planning technical staff. He has more than 15 years of experience as a project manager in the civil transportation discipline, and his background includes acting as a lead engineer for airport improvement projects from concept to completion, such as airside and landside improvements and planning efforts, runway and taxiway improvements, terminal area improvements, airfield lighting, drainage, entrance roads, hangar construction, and airport layout plans. He also has served as a roadway project engineer, completing state-, county- and municipal-sponsored projects in multiple IDOT districts, and is familiar with roadway project programming, roadway design, maintenance programs, hydrology and drainage analyses, surveying, traffic operation, and site development review.

**Relevant Project Experience:**

- Rantoul National Aviation Center, Rehabilitate Runway 18/36, Rantoul, IL
- Rantoul National Aviation Center, Rehabilitate Runway 9/27, Rantoul, IL
- Effingham County Regional Airport, Extend Runway 11/29 and Taxiway to 6,000 Feet, Effingham, IL
- Crawford County Airport, Construct New Terminal, Robinson, IL
- Crawford County Airport, Construct Parallel Taxiway to Runway 9/27, Robinson, IL
- Jacksonville Municipal Airport, Hangar and Site Improvements, Jacksonville, IL
- Jacksonville Municipal Airport, Rehabilitate Runway 13/31 and Remark Airfield, Jacksonville, IL
- Jacksonville Municipal Airport, Replace Airfield Lighting
- Jacksonville Municipal Airport, Update Airport Master Plan
- Jacksonville Municipal Airport, Construct Partial Parallel Taxiway to Runway 22

**BARRY STOLZ, PE**

Project Engineering/Civil Design

Barry has 28 years of experience in aviation, site and civil design providing cost effective planning, design and construction services related to airport/aviation development. He has extensive airport design, construction and project management experience. Having successfully managed large and small teams of personnel through complex design projects, Barry has been the project manager and/or design engineer on projects with up to \$18M in construction costs. He has been responsible for preparing and managing detailed construction safety and phasing plans, requiring coordination with airport security, ATCTs, the FAA, local emergency response organizations and other consultants during design and construction phases. Barry is knowledgeable with the latest FAA Advisory Circulars, Order documents, and technical specifications.

**Relevant Project Experience:**

- Crawford County Airport, New Terminal Building, Robinson, IL
- Crawford County Airport, Reconstruction of Southern Portion of Apron, Robinson, IL
- St. Louis Downtown Airport, Relocate/Reconstruct Taxiway B, Cahokia Heights, IL
- Edgar County Airport, Apron Expansion and Relocate/Upgrade Fuel Facility, Paris, IL
- St. Louis Regional Airport, Reconstruct T-Hangar Taxiway with PCC and Drainage Improvements, East Alton, IL
- Mt. Carmel Municipal Airport, Install a Jet-A Fuel Facility, St. Francisville, IL
- Edgar County Airport, Rehabilitate Partial Parallel Taxiway to Runway 9/27, Paris, IL
- Mt. Vernon Outland Airport, Replace Runway and Taxiway Lighting, Mt. Vernon, IL
- Salem-Leckrone Airport, Install Avgas Fuel System, Salem, IL

**Education:**

- » BS / 2009 / Civil Engineering / Southern Illinois University at Edwardsville

**Registrations & Certifications:**

- » Professional Engineer / IL
- » Private Pilot, Single Engine Land

**Education:**

- » BS / 1997 / Civil Engineering / Purdue University

**Registrations & Certifications:**

- » Professional Engineer / IL, AR, FL, GA, IA, IN, KS, KY, MO, OH

**MIKE DUDAS, PE**

Construction Administration

- » BS / Civil Engineering
- » PE / IL

Mike serves as Hanson's Construction Observation Discipline Manager and has more than 17 years of engineering, planning, and environmental compliance experience. He performs airfield geometric, grading and drainage, and pavement design, and is a key member of our production team. He also assists on the development of planning documents and the completion of environmental compliance reports. Mike also brings a year and a half of experience as an airport engineer and planner for IDOT-Aeronautics.

- Rantoul National Aviation Center, Runway 18/36 Rehabilitation, Rantoul, IL
- Jacksonville Municipal Airport, Construct 10-Unit T-Hangar, Jacksonville, IL
- Jacksonville Municipal Airport, Replace Airfield Lighting, Jacksonville, IL
- Jacksonville Municipal Airport, Construct Partial Parallel Taxiway to Runway 22, Jacksonville, IL

**SUSAN ZELLERS, PE, AAE, ENV SP**

Airport Planning

- » MS / Civil Engineering; BS / Civil Engineering
- » PE / IL
- » ISI Envision Sustainability Professional

Susan has 34 years of experience in airport planning, design, and management. With her engineering background, she focuses on developing sustainable plans that can be implemented. Over her career, Susan has provided service to more than 50 airports ranging from medium hub to general aviation airports. In addition, she brings to her work five years of airport management experience for IAA. As Deputy Director of Planning and Development, she directed the planning, engineering and construction for IND and its five reliever airports. She was also responsible for the capital improvement planning and capital project implementation for all six IAA airports.

- Effingham County Regional Airport, Master Plan Update, Effingham, IL
- Crawford County Airport, Airport Layout Plan and Narrative Report, Robinson, IL
- Litchfield Municipal Airport, Master Plan Update, Litchfield, IL
- Monmouth Municipal Airport, Airport Layout Plan Phase II, Monmouth, IL

**KATE BECKEMEYER, EI**

Project Engineering/Civil Design

- » BS / Civil Engineering; AS / Engineering Science
- » Registered Engineer Intern / IL

Kate is an aviation designer whose background includes design, construction engineering and observation, reviewing pay estimates, and using surveying equipment to verify field measurements. She has also served as a construction observer for numerous airport improvement projects, including pavement rehabilitation and airfield lighting.

- Rantoul National Aviation Center, Rehabilitate Runway 18/36, Rantoul IL
- Jacksonville Municipal Airport, Rehabilitate Runway 13/31 and Remark Airfield, Jacksonville, IL
- Coles County Memorial Airport, Taxiways A and C Rehabilitation, Mattoon, IL
- Effingham County Regional Airport, Extend Runway 11/29 and Taxiway to 6,000 Feet, Effingham, IL
- Kewanee Municipal Airport, Runway Airfield Lighting Replacement, Kewanee, IL

**JEFF ALEXANDER, CM**

Airport Planning

- » BS / Business Administration/ Management; AA / Applied Engineering
- » American Association of Airport Executives

Jeff has over 21 years of professional experience and has been working for over 16 years on a variety of airport planning and construction projects, including multiple master plans and Airport Layout Plans.

- Crawford County Airport, Airport Layout Plan and Narrative Report, Robinson, IL
- Jacksonville International Airport, Master Plan Update, Jacksonville, FL
- Abraham Lincoln Capital Airport, Smart Airport Plan, Springfield, IL
- St. Louis Downtown Airport, Airport Layout Plan with Narrative Report, Cahokia Heights, IL
- Fairfield Municipal Airport, Airport Master Plan, Fairfield, IL
- ACRP Project 03-56 - Airside Planning, Design, Construction, Operations, and Maintenance: WebResource, Nationwide, US
- Illinois Department of Transportation, Illinois Statewide Aviation Plan, Statewide, IL

## MILITARY AIRPORT PROGRAM

The Rantoul National Aviation Center has officially been designated into the MAP program! The Village of Rantoul will be positioned to address the insurmountable amounts of infrastructure that need to be removed and standardized for the safety of the Rantoul National Aviation Center. The proposal prepared by Jeff Olson and Hanson, coordinated with the Village, and accepted by the FAA, provides a sustainable approach that involves removal of the abandoned pavements, rehabilitation of the lighting and drainage affected by removals, and recycling of the removed pavements into base material for the construction of taxiways. Expansion of support facilities, such as hangar buildings, are proposed to account for the growth of the airport as a civilian airport with the large former Air Force hangars no longer for aeronautical use or associated with the current public airport.

**Your project manager, Jeff, and Hanson Professional Services celebrate your recent designation into MAP along with you and look forward to working with you on many more improvement projects in the future.**



Expand Terminal/Hangar Area

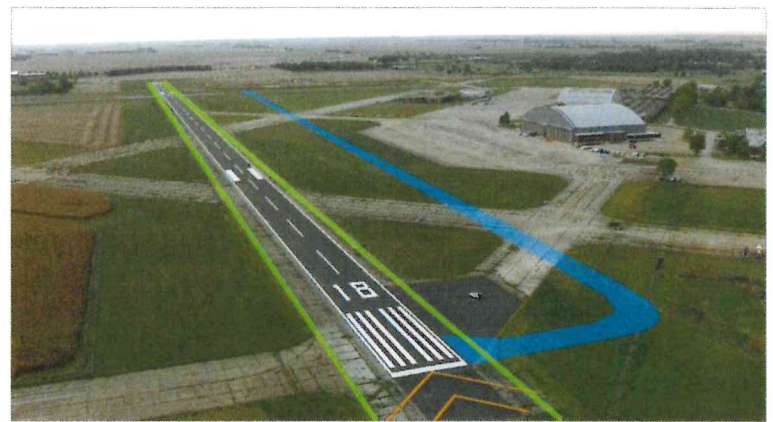

Remove Unused Runways/Taxiways, Remove Excess Width on Runway 18/36, Add New Lighting/Drainage/Taxiway

## LEADERS AND POLICYMAKERS IN THE AVIATION INDUSTRY

Beyond our knowledge of federal and state standards, Hanson also keeps up with the latest trends and flows of the aviation industry. We follow and attend meetings with organizations such as the Illinois Public Airport Association (IPAA), Airport Consultants Council (ACC), American Association of Airport Executives (AAAE), Aircraft Owners and Pilots Association (AOPA), National Association of State Aviation Officials (NASAO), and Airport Cooperative Research Program (ACRP). With Hanson staff participating on various boards and committees as part of these groups, we are sitting shoulder to shoulder with other leaders in the industry, both locally and nationwide, as discussions on the future of aviation take place. Getting in front of future technological or regulation changes can prove beneficial and save significant design and planning effort – additional value Hanson brings to RNAC.

## IDOT PREQUALIFICATIONS

Hanson is prequalified by IDOT in the following aviation disciplines:

- Airports – Design
- Airports – Construction Inspection
- Airports – Master Planning/Airport Layout Plans
- Environmental Reports – Environmental Assessment
- Airports – Design: Complex Electrical
- Airports – Construction Inspection: Complex Electrical

## ILLINOIS AND FAA GREAT LAKES REGION AIRPORTS

Hanson is currently providing general consulting services as the prime consultant in multiple states and FAA regions. These airports range from general aviation to commercial service airports and Part 139 relievers. In the Great Lakes Region, that includes Illinois and Indiana. The following list and map provides a complete listing of the airport clients served within the last three years.

### HANSON'S FAA GREAT LAKES REGION AIRPORT EXPERIENCE

#### ILLINOIS

- Abraham Lincoln Capital Airport
- Bult Field
- Casey Municipal Airport
- Coles County Memorial Airport
- Crawford County Airport
- Decatur Airport
- Edgar County Airport
- Effingham County Regional Airport
- Fairfield Municipal Airport
- Flora Municipal Airport
- Galesburg Municipal Airport
- Greater Beardstown Airport
- Greenville Airport
- Havana Regional Airport
- Ingersoll Airport
- Jacksonville Municipal Airport
- Joliet Regional Airport
- Kewanee Municipal Airport
- Lawrenceville-Vincennes International Airport
- Lewis University Airport
- Litchfield Municipal Airport
- Logan County Airport
- Macomb Municipal Airport
- Marshall County Airport
- Monmouth Municipal Airport
- Morris Municipal Airport
- Mount Carmel Municipal Airport
- Mount Sterling Municipal Airport
- Mount Vernon Outland Airport
- Olney-Noble Airport
- Pekin Municipal Airport
- Pittsfield Penstone Municipal Airport
- Rantoul National Aviation Center
- Rochelle Municipal Airport
- Salem-Leckrone Airport
- Shelby County Airport
- Southern Illinois Airport
- St. Louis Downtown Airport
- St. Louis Regional Airport
- Tri-Township Airport
- Vandalia Municipal Airport

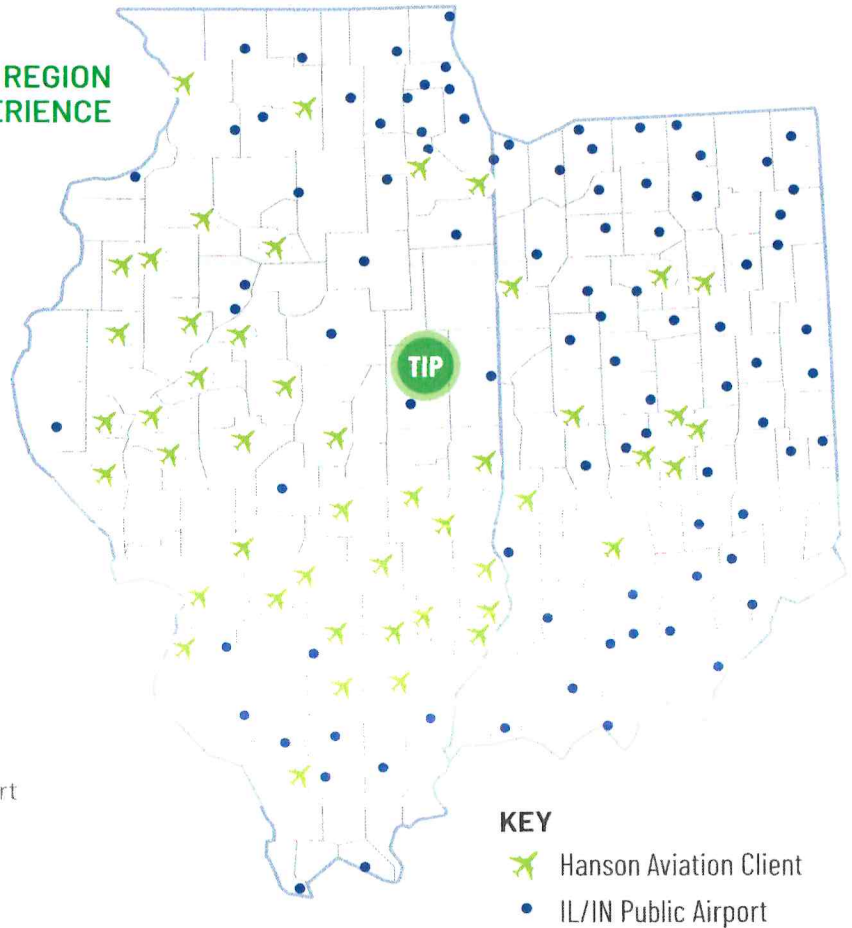

#### KEY

- ✈ Hanson Aviation Client
- IL/IN Public Airport

#### INDIANA

- Crawfordsville Regional Airport
- Fort Wayne International Airport
- Indianapolis International Airport
- Indianapolis Metropolitan Airport
- Indianapolis Regional Airport
- Indy South Greenwood Airport
- Kentland Municipal Airport
- Monroe County Airport
- Peru Municipal Airport
- Terre Haute Regional Airport
- Wabash Municipal Airport



**INNOVATIVE  
ENGINEERING  
FOR A BETTER  
PLANET.**

Copyright © 2026 by Hanson Professional Services Inc. All rights reserved. This document is intended solely for the individual or the entity to which it is addressed. The information contained in this document shall not be duplicated, stored electronically, or distributed, in whole or in part, by anyone other than the recipient without the express written permission of Hanson Professional Services Inc., 1525 S. Sixth St., Springfield, IL 62703, (217) 788-2450, [www.hanson-inc.com](http://www.hanson-inc.com). Unauthorized reproduction or transmission of any part of this document is a violation of federal law. Any concepts, designs and project approaches contained herein are considered proprietary. Any use of these concepts and approaches by others is considered a violation of copyright law.

**BOARD OF TRUSTEES  
VILLAGE OF RANTOUL**

**AGENDA ITEM**

ITEM: Rantoul National Aviation Center Quarterly Report	DEPARTMENT: Administration
DATE: July 7, 2026	AMOUNT:
ATTACHMENTS:	ADMINISTRATIVE NOTES:
SUMMARY HIGHLIGHTS:	
RECOMMENDED ACTION:	
DEPARTMENT HEAD APPROVAL Bob Coverdill	VILLAGE ADMINISTRATOR Scott Eisenhauer

**BOARD OF TRUSTEES  
VILLAGE OF RANTOUL**

**AGENDA ITEM**

<p>ITEM: Contract for the Construction of the Pleasant Acres Sidewalk Connections Project with A&amp;A Concrete, LLC. in the amount of \$428,855.00</p>	<p>DEPARTMENT: Community Planning &amp; Development</p>
<p>DATE: July 7, 2026</p>	<p>AMOUNT: Total Contract - \$428,855.00 100% ITEP Grant Funded</p>
<p>ATTACHMENTS:  1. Pleasant Acres Sidewalk Project</p>	<p>ADMINISTRATIVE NOTES:</p>

**SUMMARY HIGHLIGHTS:**

This item provides for the construction of the Pleasant Acres Sidewalks project. The project will consist of the construction of new sidewalks, including connecting to and extending existing sidewalks, starting at Winston Park and along Gates Drive on the North, and then continuing along Eater Drive to Harper Drive where the proposed sidewalks would match up with the recently completed sidewalk installed as part of the last Safe Routes to School Project. The sidewalks will then continue along Eater until they match up with existing sidewalks farther South in that neighborhood. There is a map in your packet depicting this area.

The project was advertised for bid in May, and bids were received and opened on June 12, 2026. A total of six (6) bids were received, and the bid tabulation is attached for reference. A low bid in the amount of \$428,855.00 was provided by A&A Concrete, LLC, which is the same contractor that has previously performed some sidewalk work for the Village. Staff determined that the bid and bidder met all requirements, and thus this bid is being recommended for acceptance.

The construction of this project would be paid for completely from grant funding, specifically Illinois Transportation Enhancement Program (ITEP) funds awarded from the Illinois Department of Transportation (IDOT).

It is anticipated construction would start sometime in August and take approximately two months to complete.

**RECOMMENDED ACTION:** Authorize the acceptance of the bid and awarding of a

contract to A&A Concrete, LLC. in the amount of \$428,855.00 for the construction of the Pleasant Acres Sidewalk Connections Project.

DEPARTMENT HEAD APPROVAL  
Chris Milliken

VILLAGE ADMINISTRATOR  
Scott Eisenhauer

**INDEX OF SHEETS**

- 01 COVER SHEET
- 02-03 GENERAL NOTES, & LEGENDS
- 04 SUMMARY OF QUANTITIES
- 05 TYPICAL SECTION
- 06-09 SCHEDULE OF QUANTITIES
- 10-12 REMOVAL PLAN
- 13-17 PLAN & PROFILE
- 18-20 ADA DETAIL SHEET
- 21-23 EROSION CONTROL PLANS
- 24-42 CROSS SECTION

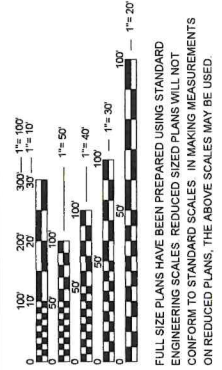

PROJECT LOCATION  
EATER DR.  
(FROM SHORT ST. TO  
GATES DR.)

STATE OF ILLINOIS  
DEPARTMENT OF TRANSPORTATION  
DIVISION OF HIGHWAYS  
**THE VILLAGE OF RANTOUL**  
CONSTRUCTION PLANS FOR  
**PLEASANT ACRES SIDEWALK - PH 1-11**  
SECTION 23-00117-00-BT  
CHAMPAIGN COUNTY  
CONTRACT 250050

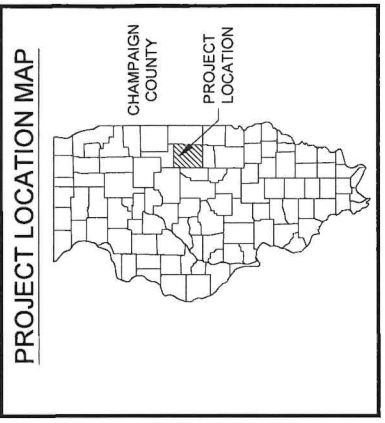

LOCATION MAP  
NOT TO SCALE

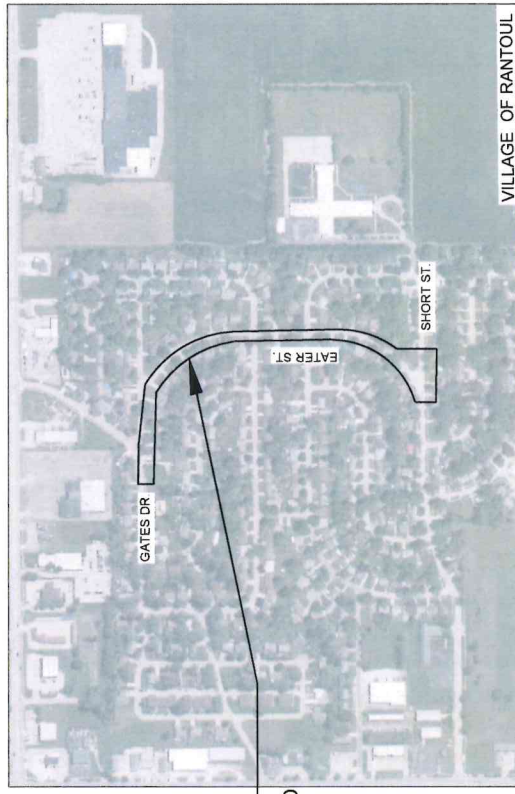

LOCATION MAP  
NET LENGTH OF PROJECT = 2501 FT = 0.47 MILES  
GROSS LENGTH OF PROJECT = 2501 FT = 0.47 MILES

JOINT UTILITY LOCATION INFORMATION FOR EXCAVATION  
1-800-892-0123  
OR 811

**Hutchison**  
Engineering, Inc.  
PROJECT MANAGER: ANDY HUFTALIN  
PROJECT ENGINEER: DEVON LEACH

CONTRACT NO. 250050

APPROVED \_\_\_\_\_ 20 \_\_\_\_\_  
LOCAL AGENCY OFFICIAL

PASSED \_\_\_\_\_ 20 \_\_\_\_\_  
DISTRICT FIVE ENGINEER OF  
LOCAL ROADS & STREETS

Releasing For  
Bid Based on  
Limited Review \_\_\_\_\_ 20 \_\_\_\_\_  
REGION THREE ENGINEER  
STATE OF ILLINOIS  
DEPARTMENT OF TRANSPORTATION

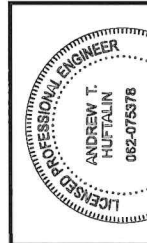

EXPIRES: 11/30/27  
**ENGINEER'S SEAL**

**ENGINEER'S CERTIFICATE**

I HEREBY CERTIFY THAT THIS ENGINEERING DOCUMENT WAS PREPARED BY ME OR UNDER MY DIRECT PERSONAL SUPERVISION AND THAT I AM A DULY LICENSED PROFESSIONAL ENGINEER UNDER THE LAWS OF THE STATE OF ILLINOIS.



**Hutchison**  
Engineering, Inc.  
Since 1945

June 16, 2026

Chad Isley  
Public Works Director  
Village of Rantoul  
333 South Tanner St,  
Rantoul, IL, 61866

Re: Award Recommendation – Pleasant Acres Sidewalk

Dear Mr. Isley:

As requested, we have reviewed the six (6) proposals received at the bid opening held at the office on June 12, 2026 for the above noted project (see attached bid tab). A&A Concrete Inc. submitted the apparent low Total Bid in the amount of \$428,855.00. This amount is 15% lower than our estimate of cost of \$502,768.87.

A&A Concrete, Inc. appears to have fully completed their bid proposal and submitted the necessary executed forms with their bid proposal. They submitted a Bid Bond for 5% of the amount bid. A&A Concrete Inc., as a corporation, included all necessary signatures and dates. Therefore, we find A&A Concrete Inc. to be both 'responsive' and 'responsible' as defined in the bidding documents and recommend the Village of Rantoul accept the bid proposal from them and award the Contract to them in the amount of \$428,855.00.

Upon notification the Village of Rantoul approves the bid, we will deliver the Notice of Award along with the Contract and Contract Bond forms to A&A Concrete Inc. for their execution.

Very truly yours,

Hutchison Engineering Inc.

W. Shane Larson, P.E.  
Senior Vice President

Attach.

**Jacksonville**  
1801 W Lafayette Ave  
Jacksonville, IL 62651  
(217) 245-7164

**Shorewood**  
605 Rollingwood Dr  
Shorewood, IL 60404  
(815) 733-6295

**Peoria**  
8305 N Allen Rd,  
Suite 4  
Peoria, IL 61615  
(309) 691-1366

**Quad Cities**  
1701 River Dr,  
Suite 110  
Moline, IL 61265  
(309) 517-3899

**Carbondale**  
1335 North Cedar Court  
Carbondale, IL 62901  
(618) 457-2188

**Hannibal**  
8965 Highway 36,  
Suite 5  
Hannibal, MO 63401  
(573) 240-9577

**Beloit**  
690 Third St,  
Suite 230  
Beloit, WI 53511  
(608) 368-8025



Owner: Village of Ramothul  
 Project: Pleasant Acres Sidewalk  
 Date: June 12, 2026  
 Time: 11:00:00 AM

Item No.	Items	Unit	Quantity	Name of Bidder			CROSS CONSTRUCTION, INC.			FUEZ CONTRACTORS, INC.			DUCE CONSTRUCTION CO			MID-ILLINOIS CONCRETE			SNC CONSTRUCTION INC		
				Price	Total	Unit Price	Address of Bidder	URBANA, IL 61802	URBANA, IL 61802	CHAMPAIGN, IL 61802	CHAMPAIGN, IL 61802	CHAMPAIGN, IL 61802	CHAMPAIGN, IL 61802	CHAMPAIGN, IL 61802	CHAMPAIGN, IL 61802	CHAMPAIGN, IL 61802	CHAMPAIGN, IL 61802	CHAMPAIGN, IL 61802	CHAMPAIGN, IL 61802	CHAMPAIGN, IL 61802	CHAMPAIGN, IL 61802
20101100	TREE TRUNK PROTECTION	EACH	12	\$331.23	\$3,974.76	\$329.50	\$1,200.00	\$1,980.00	\$165.00	\$1,980.00	\$300.00	\$3,600.00	\$100.00	\$1,200.00	\$1,000.00	\$1,200.00	\$1,000.00	\$1,200.00	\$140.33	\$1,683.96	
21101600	TOPSOIL EXC & PLAC	CU YD	60	\$80.00	\$4,800.00	\$80.00	\$4,800.00	\$4,800.00	\$41.00	\$2,460.00	\$110.00	\$6,600.00	\$150.00	\$9,000.00	\$150.00	\$9,000.00	\$150.00	\$9,000.00	\$29.89	\$1,793.40	
25100630	EROSION CONTR BLANKET	SQ YD	1,053	\$2.07	\$2,179.71	\$4.00	\$4,212.00	\$3,200.00	\$3.20	\$3,369.60	\$7.50	\$7,897.50	\$2.10	\$2,211.30	\$2.50	\$2,632.50	\$4.71	\$4,952.81	\$4.71	\$5,022.81	
28000400	PERIMETER EROD BAR	FOOT	500	\$4.65	\$2,325.00	\$6.00	\$3,000.00	\$4,000.00	\$7.50	\$3,750.00	\$20.00	\$10,000.00	\$30.00	\$15,000.00	\$4.00	\$2,000.00	\$4.00	\$2,000.00	\$4.78	\$2,390.00	
38000510	INLET FILTERS	EACH	11	\$295.00	\$3,245.00	\$225.00	\$2,475.00	\$4,000.00	\$350.00	\$3,850.00	\$300.00	\$3,300.00	\$230.00	\$2,530.00	\$230.00	\$2,530.00	\$230.00	\$2,530.00	\$384.50	\$4,229.50	
35101600	AGG BASE CSE B 4	SQ YD	2,264	\$13.40	\$30,337.60	\$9.50	\$21,508.00	\$13,200.00	\$17.20	\$38,880.00	\$13.50	\$30,564.00	\$14.00	\$31,696.00	\$14.00	\$31,696.00	\$13.50	\$30,564.00	\$17.34	\$39,257.76	
40200300	AGG SURE CSE A 4	SQ YD	121	\$21.00	\$2,541.00	\$28.00	\$3,388.00	\$3,000.00	\$17.00	\$2,046.00	\$26.00	\$3,138.00	\$26.00	\$3,138.00	\$26.00	\$3,138.00	\$26.00	\$3,138.00	\$20.76	\$2,511.96	
40201000	AGGREGATE-TEMP ACCESS	TON	125	\$64.50	\$8,062.50	\$16.00	\$2,000.00	\$65.00	\$8,125.00	\$73.00	\$9,125.00	\$62.00	\$7,750.00	\$93.00	\$11,625.00	\$93.00	\$11,625.00	\$85.47	\$10,683.75		
42300200	PC DRIVEWAY PAVT 5	SQ YD	979	\$106.00	\$103,774.00	\$78.50	\$76,851.50	\$86.00	\$84,194.00	\$90.00	\$88,110.00	\$90.00	\$88,110.00	\$100.00	\$97,900.00	\$100.00	\$97,900.00	\$97.67	\$95,618.93		
42300200	PC CONIC SIDEWALK 5	SQ FT	9,710	\$10.50	\$101,955.00	\$8.25	\$80,107.50	\$11.00	\$107,781.00	\$10.30	\$100,013.00	\$10.00	\$97,100.00	\$12.25	\$118,947.50	\$12.25	\$118,947.50	\$13.05	\$126,715.50		
42400800	DETECTABLE WARNINGS	SQ FT	86	\$43.00	\$3,698.00	\$42.00	\$3,612.00	\$40.00	\$3,440.00	\$39.00	\$3,363.00	\$35.00	\$3,015.00	\$35.00	\$3,015.00	\$35.00	\$3,015.00	\$35.00	\$3,015.00	\$47.80	\$4,110.80
44000100	PAVEMENT REM	SQ YD	846	\$39.00	\$33,006.00	\$20.00	\$16,920.00	\$30.00	\$25,380.00	\$16.00	\$13,536.00	\$27.00	\$22,842.00	\$26.00	\$22,164.00	\$26.00	\$22,164.00	\$26.00	\$22,164.00	\$48.90	\$41,369.40
44000200	DRIVE PAVEMENT REM	SQ YD	846	\$30.00	\$25,380.00	\$20.00	\$16,920.00	\$30.00	\$25,380.00	\$18.00	\$15,216.00	\$18.00	\$15,216.00	\$18.00	\$15,216.00	\$18.00	\$15,216.00	\$18.00	\$15,216.00	\$17.84	\$14,895.68
44000300	CURB REM	FOOT	502	\$10.50	\$5,271.00	\$11.00	\$5,522.00	\$10.00	\$5,020.00	\$13.00	\$6,570.00	\$13.00	\$6,570.00	\$13.00	\$6,570.00	\$13.00	\$6,570.00	\$13.00	\$6,570.00	\$17.84	\$8,955.68
44000600	CLD SIDEWALK REM	SQ FT	2,586	\$3.25	\$8,404.50	\$3.00	\$7,758.00	\$10.00	\$25,860.00	\$2.30	\$5,947.80	\$3.00	\$7,758.00	\$4.50	\$11,637.00	\$4.50	\$11,637.00	\$5.00	\$12,930.00	\$5.00	\$12,930.00
44201690	CLD PATCH T1 4	SQ YD	18	\$113.00	\$2,034.00	\$100.00	\$1,800.00	\$120.00	\$2,160.00	\$140.00	\$2,520.00	\$292.00	\$5,256.00	\$280.00	\$5,040.00	\$280.00	\$5,040.00	\$280.00	\$5,040.00	\$189.33	\$3,407.94
44201692	CLD PATCH T2 4	SQ YD	126	\$79.00	\$9,954.00	\$85.00	\$10,710.00	\$100.00	\$12,600.00	\$120.00	\$15,120.00	\$238.00	\$29,988.00	\$215.00	\$27,090.00	\$215.00	\$27,090.00	\$215.00	\$27,090.00	\$148.46	\$18,705.96
44201694	CLD PATCH T3 4	SQ YD	22	\$85.00	\$1,870.00	\$80.00	\$1,760.00	\$120.00	\$2,640.00	\$115.00	\$2,530.00	\$197.35	\$4,341.70	\$180.00	\$5,760.00	\$180.00	\$5,760.00	\$180.00	\$5,760.00	\$176.59	\$3,884.98
56109210	WATER VALVES ADJUST	EACH	3	\$1,850.00	\$5,550.00	\$200.00	\$600.00	\$550.00	\$1,650.00	\$75.00	\$5,625.00	\$900.00	\$2,700.00	\$225.00	\$675.00	\$225.00	\$675.00	\$225.00	\$675.00	\$301.65	\$904.95
60255500	MAN ADJUST	EACH	2	\$1,675.00	\$3,350.00	\$500.00	\$1,000.00	\$500.00	\$500.00	\$765.00	\$1,530.00	\$900.00	\$1,800.00	\$225.00	\$450.00	\$225.00	\$450.00	\$225.00	\$450.00	\$112.36	\$2,186.36
60260100	INLET ADJUST	EACH	1	\$1,100.00	\$1,100.00	\$500.00	\$500.00	\$700.00	\$700.00	\$700.00	\$700.00	\$700.00	\$700.00	\$700.00	\$700.00	\$700.00	\$700.00	\$700.00	\$700.00	\$700.00	\$700.00
60603800	COMB C&G TB6 12	FOOT	854	\$81.00	\$69,174.00	\$53.50	\$45,689.00	\$74.00	\$63,196.00	\$70.00	\$59,401.00	\$82.00	\$70,028.00	\$64.50	\$55,083.00	\$64.50	\$55,083.00	\$64.50	\$55,083.00	\$72.88	\$62,239.52
60605100	COMB C&G TY B-4-24	FOOT	119	\$112.00	\$13,328.00	\$55.00	\$6,545.00	\$76.00	\$9,044.00	\$79.00	\$9,401.00	\$90.00	\$10,710.00	\$69.00	\$8,211.00	\$69.00	\$8,211.00	\$69.00	\$8,211.00	\$87.90	\$10,460.10
67001100	MOBILIZATION	L SUM	1	\$15,000.00	\$15,000.00	\$8,600.00	\$8,600.00	\$5,500.00	\$5,500.00	\$43.00	\$43.00	\$31,000.00	\$31,000.00	\$31,000.00	\$31,000.00	\$31,000.00	\$31,000.00	\$31,000.00	\$31,000.00	\$46.80	\$46.80
78000400	TRPL PVT MK LINE 6	FOOT	277	\$4.90	\$1,357.30	\$41.00	\$11,387.00	\$50.00	\$13,850.00	\$8.20	\$2,261.40	\$40.00	\$11,080.00	\$45.00	\$12,465.00	\$45.00	\$12,465.00	\$45.00	\$12,465.00	\$30.05	\$8,315.23
20013798	CONSTRUCTION LAYOUT	EACH	34	\$115.00	\$3,910.00	\$44.00	\$1,496.00	\$50.00	\$1,700.00	\$80.00	\$2,720.00	\$155.00	\$5,270.00	\$115.00	\$3,910.00	\$115.00	\$3,910.00	\$115.00	\$3,910.00	\$91.49	\$3,129.22
XZ020410	EARTH EXCAVATION SPL	CU YD	367	\$30.00	\$11,010.00	\$30.00	\$11,010.00	\$55.00	\$20,175.00	\$42.00	\$15,414.00	\$70.00	\$25,690.00	\$82.00	\$30,094.00	\$82.00	\$30,094.00	\$82.00	\$30,094.00	\$77.42	\$28,292.78
X7010216	TRAFFIC CONT & PROT SPL	L SUM	1	\$20,000.00	\$20,000.00	\$4,000.00	\$4,000.00	\$6,500.00	\$6,500.00	\$6,900.00	\$6,900.00	\$11,000.00	\$11,000.00	\$12,240.00	\$12,240.00	\$12,240.00	\$12,240.00	\$12,240.00	\$12,240.00	\$5,057.87	\$5,057.87
X8404010	REL LP W/LUMINAIRE	EACH	1	\$1,200.00	\$1,200.00	\$1,300.00	\$1,300.00	\$3,000.00	\$3,000.00	\$3,600.00	\$3,600.00	\$4,200.00	\$4,200.00	\$4,200.00	\$4,200.00	\$4,200.00	\$4,200.00	\$4,200.00	\$4,200.00	\$6,193.73	\$6,193.73
XX000001	LANDSCAPE SPL	L SUM	1	\$5,000.00	\$5,000.00	\$1,600.00	\$1,600.00	\$4,200.00	\$4,200.00	\$4,300.00	\$4,300.00	\$4,300.00	\$4,300.00	\$4,300.00	\$4,300.00	\$4,300.00	\$4,300.00	\$4,300.00	\$4,300.00	\$4,300.00	\$4,300.00
XX000002	SEEDING CLASS 1 SPL	SQ YD	1053	\$8.00	\$8,424.00	\$2.00	\$2,106.00	\$4.00	\$4,212.00	\$2.90	\$3,053.70	\$5.35	\$5,633.55	\$6.00	\$6,318.00	\$6.00	\$6,318.00	\$6.00	\$6,318.00	\$3.70	\$3,896.10
XX000003	MULCH METHOD 1 SPL	SQ YD	1053	\$7.50	\$7,897.50	\$2.00	\$2,106.00	\$2.00	\$2,106.00	\$0.55	\$579.15	\$1.65	\$1,737.45	\$2.00	\$2,106.00	\$2.00	\$2,106.00	\$2.00	\$2,106.00	\$4.16	\$4,380.48
<b>Total =</b>				<b>\$502,766.87</b>	<b>\$428,855.00</b>	<b>\$428,855.00</b>	<b>\$428,855.00</b>	<b>\$428,855.00</b>	<b>\$428,855.00</b>	<b>\$428,855.00</b>	<b>\$428,855.00</b>	<b>\$428,855.00</b>	<b>\$428,855.00</b>	<b>\$428,855.00</b>	<b>\$428,855.00</b>	<b>\$428,855.00</b>	<b>\$428,855.00</b>	<b>\$428,855.00</b>	<b>\$428,855.00</b>	<b>\$428,855.00</b>	<b>\$428,855.00</b>



**Hutchison**  
Engineering, Inc.

**Bid Summary**

**Project:** Pleasant Acres Sidewalk

**Owner:** Village of Rantoul

**Engineer's Estimate:** \$502,701.43

<b>Contractor</b>	<b>Bid Amount</b>
Mid - Illinois Concrete	\$ 570,630.00
Cross Construction	\$ 462,604.00
Fentz Contractors	\$ 462,744.60
A & A Concrete Inc	\$ 428,855.00
SNC Construction, Inc	\$ 580,826.74
Duce Construction, Inc	\$ 523,886.00



COVER SHEET

<b>Proposal Submitted By:</b> Contractor's Name A&A Concrete, LLC				
Contractor's Address 3107 N. Lincoln Avenue		City Urbana	State IL	Zip Code 61802

STATE OF ILLINOIS		
Local Public Agency	County	Section Number
Village of Rantoul	Champaign	24-00118-00-SW

Route(s) (Street/Road Name)	Type of Funds
Eater Drive	ITEP

Proposal Only  
  Proposal and Plans  
  Proposal only, plans are separate

Submitted/Approved  
For Local Public Agency:

<b>For a County and Road District Project</b>  Submitted/Approved Highway Commissioner Signature & Date <div style="border: 1px solid black; height: 30px; width: 100%;"></div> Submitted/Approved County Engineer/Superintendent of Highways Signature & Date <div style="border: 1px solid black; height: 30px; width: 100%;"></div>
---

<b>For a Municipal Project</b>  Submitted/Approved/Passed Signature & Date <div style="border: 1px solid black; padding: 5px;"> <i>Chad Tolly</i>    5/15/2026         </div> Official Title <div style="border: 1px solid black; padding: 5px;">           DIRECTOR OF PUBLIC WORKS         </div>
--

<b>Department of Transportation</b>  Released for bid based on limited review Regional Engineer Signature & Date <div style="border: 1px solid black; padding: 5px;"> <i>Ronald A. Garnett</i>    051326         </div>
---

Note: All proposal documents, including Proposal Guaranty Checks or Proposal Bid Bonds, should be stapled together to prevent loss when bids are processed.

Local Public Agency	County	Section Number	Route(s) (Street/Road Name)
Village of Rantoul	Champaign	24-00118-00-SW	Eater Drive

**NOTICE TO BIDDERS**

Sealed proposals for the project described below will be received at the office of \_\_\_\_\_  
 333 South Tanner St, Rantoul, IL 61866 \_\_\_\_\_ until 11:00 AM on 06-12-26  
 Address Time Date

Sealed proposals will be opened and read publicly at the office of \_\_\_\_\_  
 333 South Tanner St, Rantoul, IL 61866 \_\_\_\_\_ at 11:00 AM on 06-12-26  
 Address Time Date

**DESCRIPTION OF WORK**

Location	Project Length
Pleasant Acres Sidewalk	

Proposed Improvement  
 Construction and replacement of a sidewalk path with ADA ramp improvements

1. Plans and proposal forms will be available in the office of  
 through Hutchison Engineering, Inc. website at [www.hutchisoneng.com](http://www.hutchisoneng.com) under the Bidding tab.

2.  Prequalification  
 If checked, the 2 apparent as read low bidders must file within 24 hours after the letting an "Affidavit of Availability" (Form BC 57) in triplicate, showing all uncompleted contracts awarded to them and all low bids pending award for Federal, State, County, Municipal and private work. One original shall be filed with the Awarding Authority and two originals with the IDOT District Office.
3. The Awarding Authority reserves the right to waive technicalities and to reject any or all proposals as provided in BLRS Special Provision for Bidding Requirements and Conditions for Contract Proposals.
4. The following BLR Forms shall be returned by the bidder to the Awarding Authority:
  - a. Local Public Agency Formal Contract Proposal (BLR 12200)
  - b. Schedule of Prices (BLR 12201)
  - c. Proposal Bid Bond (BLR 12230) (if applicable)
  - d. Apprenticeship or Training Program Certification (BLR 12325) (do not use for project with Federal funds.)
  - e. Affidavit of Illinois Business Office (BLR 12326) (do not use for project with Federal funds)
5. The quantities appearing in the bid schedule are approximate and are prepared for the comparison of bids. Payment to the Contractor will be made only for the actual quantities of work performed and accepted or materials furnished according to the contract. The scheduled quantities of work to be done and materials to be furnished may be increased, decreased or omitted as hereinafter provided.
6. Submission of a bid shall be conclusive assurance and warranty the bidder has examined the plans and understands all requirements for the performance of work. The bidder will be responsible for all errors in the proposal resulting from failure or neglect to conduct an in depth examination. The Awarding Authority will, in no case, be responsible for any costs, expenses, losses or changes in anticipated profits resulting from such failure or neglect of the bidder.
7. The bidder shall take no advantage of any error or omission in the proposal and advertised contract.
8. If a special envelope is supplied by the Awarding Authority, each proposal should be submitted in that envelope furnished by the Awarding Agency and the blank spaces on the envelope shall be filled in correctly to clearly indicate its contents. When an envelope other than the special one furnished by the Awarding Authority is used, it shall be marked to clearly indicate its contents. When sent by mail, the sealed proposal shall be addressed to the Awarding Authority at the address and in care of the official in whose office the bids are to be received. All proposals shall be filed prior to the time and at the place specified in the Notice to Bidders. Proposals received after the time specified will be returned to the bidder unopened.
9. Permission will be given to a bidder to withdraw a proposal if the bidder makes the request in writing or in person before the time for opening proposals.

Local Public Agency	County	Section Number	Route(s) (Street/Road Name)
Village of Rantoul	Champaign	24-00118-00-SW	Eater Drive

**PROPOSAL**

**A&A Concrete, LLC**

1. Proposal of \_\_\_\_\_  

Contractor's Name  
**3107 N. Lincoln Avenue Urbana, IL 61802**

---

Contractor's Address
2. The plans for the proposed work are those prepared by \_\_\_\_\_  
and approved by the Department of Transportation on \_\_\_\_\_.
3. The specifications referred to herein are those prepared by the Department of Transportation and designated as "Standard Specifications for Road and Bridge Construction" and the "Supplemental Specifications and Recurring Special Provisions" thereto, adopted and in effect on the date of invitation for bids.
4. The undersigned agrees to accept, as part of the contract, the applicable Special Provisions indicated on the "Check Sheet for Recurring Special Provisions" contained in this proposal.
5. The undersigned agrees to complete the work within \_\_\_\_\_ working days or by 09/04/26 unless additional time is granted in accordance with the specifications.
6. The successful bidder at the time of execution of the contract will be required to deposit a contract bond for the full amount of the award. When a contract bond is not required, the proposal guaranty check will be held in lieu thereof. If this proposal is accepted and the undersigned fails to execute a contract and contract bond as required, it is hereby agreed that the Bid Bond of check shall be forfeited to the Awarding Authority.
7. Each pay item should have a unit price and a total price. If no total price is shown or if there is a discrepancy between the products of the unit price multiplied by the quantity, the unit price shall govern. If a unit price is omitted, the total price will be divided by the quantity in order to establish a unit price. A bid may be declared unacceptable if neither a unit price nor a total price is shown.
8. The undersigned submits herewith the schedule of prices on BLR 12201 covering the work to be performed under this contract.
9. The undersigned further agrees that if awarded the contract for the sections contained in the combinations on BLR 12201, the work shall be in accordance with the requirements of each individual proposal for the multiple bid specified in the Schedule for Multiple Bids below.
10. A proposal guaranty in the proper amount, as specified in BLRS Special Provision for Bidding Requirements and Conditions for Contract Proposals, will be required. Bid Bonds Will be allowed as a proposal guaranty. Accompanying this proposal is either a bid bond, if allowed, on Department form BLR 12230 or a proposal guaranty check, complying with the specifications, made payable to: \_\_\_\_\_ Treasurer of \_\_\_\_\_.  
The amount of the check is \_\_\_\_\_ ( \_\_\_\_\_ ).

**Bid Bond attached.**

<p><b>Attach Cashier's Check or Certified Check Here</b></p> <p>In the event that one proposal guaranty check is intended to cover two or more bid proposals, the amount must be equal to the sum of the proposal guaranties which would be required for each individual bid proposal. If the proposal guaranty check is placed in another bid proposal, state below where it may be found.</p> <p>The proposal guaranty check will be found in the bid proposal for: Section Number <u>24-00118-00-SW</u></p>
--

Local Public Agency	County	Section Number	Route(s) (Street/Road Name)
Village of Rantoul	Champaign	24-00118-00-SW	Eater Drive

### CONTRACTOR CERTIFICATIONS

The certifications hereinafter made by the bidder are each a material representation of fact upon which reliance is placed should the Department enter into the contract with the bidder.

1. **Debt Delinquency.** The bidder or contractor or subcontractor, respectively, certifies that it is not delinquent in the payment of any tax administered by the Department of Revenue unless the individual or other entity is contesting, in accordance with the procedure established by the appropriate Revenue Act, its liability for the tax or the amount of the tax. Making a false statement voids the contract and allows the Department to recover all amounts paid to the individual or entity under the contract in a civil action.
2. **Bid-Rigging or Bid Rotating.** The bidder or contractor or subcontractor, respectively, certifies that it is not barred from contracting with the Department by reason of a violation of either 720 ILCS 5/33E-3 or 720 ILCS 5/33E-4.

A violation of section 33E-3 would be represented by a conviction of the crime of bid-rigging which, in addition to Class 3 felony sentencing, provides that any person convicted of this offense, or any similar offense of any state or the United States which contains the same elements as this offense shall be barred for 5 years from the date of conviction from contracting with any unit of State or local government. No corporation shall be barred from contracting with any unit of State or local government as a result of a conviction under this Section of any employee or agent of such corporation if the employee so convicted is no longer employed by the corporation: (1) it has been finally adjudicated not guilty or (2) if it demonstrates to the governmental entity with which it seeks to contract that entity finds that the commission of the offense was neither authorized, requested, commanded, nor performed by a director, officer or a high managerial agent on behalf of the corporation.

A violation of Section 33E-4 would be represented by a conviction of the crime of bid-rotating which, in addition to Class 2 felony sentencing, provides that any person convicted of this offense or any similar offense of any state or the United States which contains the same elements as this offense shall be permanently barred from contracting with any unit of State or Local government. No corporation shall be barred from contracting with any unit of State or Local government as a result of a conviction under this Section of any employee or agent of such corporation if the employee so convicted is no longer employed by the corporation and: (1) it has been finally adjudicated not guilty or (2) if it demonstrates to the governmental entity with which it seeks to contract and that entity finds that the commission of the offense was neither authorized, requested, commanded, nor performed by a director, officer or a high managerial agent on behalf of the corporation.

3. **Bribery.** The bidder or contractor or subcontractor, respectively, certifies that, it has not been convicted of bribery or attempting to bribe an officer or employee of the State of Illinois or any unit of local government, nor has the firm made an admission of guilt of such conduct which is a matter of record, nor has an official, agent, or employee of the firm committed bribery or attempted bribery on behalf of the firm and pursuant to the direction or authorization of a responsible official of the firm.
4. **Interim Suspension or Suspension.** The bidder or contractor or subcontractor, respectively, certifies that it is not currently under a suspension as defined in Subpart I of Title 44 Subtitle A Chapter III Part 6 of the Illinois Administrative code. Furthermore, if suspended prior to completion of this work, the contract or contracts executed for the completion of this work may be canceled.

Local Public Agency	County	Section Number	Route(s) (Street/Road Name)
Village of Rantoul	Champaign	24-00118-00-SW	Eater Drive

**SIGNATURES**

(If an individual)

Bidder Signature & Date

--

Business Address

--

City

State

Zip Code

--	--	--

(If a partnership)

Firm Name

--

Signature & Date

--

Title

--

Business Address

--

City

State

Zip Code

--	--	--

Insert the Names and Addresses of all Partners

--

(If a corporation)

Corporate Name

A&A Concrete, LLC
-------------------

Signature & Date

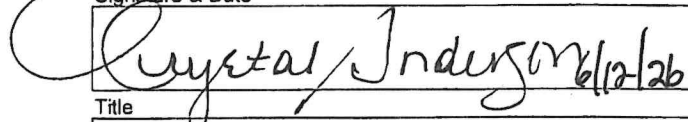
--

Title

President
-----------

Business Address

3107 N. Lincoln Avenue
------------------------

City

State

Zip Code

Urbana	IL	61802
--------	----	-------

Insert Names of Officers

President

Crystal Anderson
------------------

Attest:

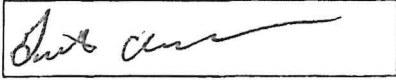

Secretary

Secretary

Garrett Anderson

Treasurer

Garrett Anderson



Contractor's Name

A&A Concrete, LLC

Contractor's Address

3107 N. Lincoln Avenue

City

Urbana

State

IL

Zip Code

61802

Local Public Agency

Village of Rantoul

County

Champaign

Section Number

24-00118-00-SW

Route(s) (Street/Road Name)

Pleasant Acres Sidewalk

Schedule for Multiple Bids

Combination Letter	Section Included in Combinations	Total

Schedule for Single Bid

(For complete information covering these items, see plans and specifications.)

Item Number	Items	Unit	Quantity	Unit Price	Total
20101100	TREE TRUNK PROTECTION	EACH	12	\$85.00	\$1,020.00
21101505	TOPSOIL EXC & PLAC	CU YD	60	\$80.00	\$4,800.00
25100630	EROSION CONTR BLANKET	SQ YD	1,053	\$4.00	\$4,212.00
28000400	PERIMETER EROS BAR	FOOT	500	\$6.00	\$3,000.00
28000500	INLET & PIPE PROTECT	EACH	11	\$225.00	\$2,475.00
35101600	AGG BASE CSE B 4	SQ YD	2,264	\$9.50	\$21,508.00
40200300	AGG SURF CSE A 4	SQ YD	121	\$28.00	\$3,388.00
40201000	AGGREGATE-TEMP ACCESS	TON	125	\$16.00	\$2,000.00
42300200	PCC DRIVEWAY PAVT 6	SQ YD	979	\$78.50	\$76,851.50
42400200	PC CONC SIDEWALK 5	SQ FT	9,710	\$8.25	\$80,167.50
42400800	DETECTABLE WARNINGS	SQ FT	86	\$42.00	\$3,612.00
44000100	PAVEMENT REM	SQ YD	219	\$18.00	\$3,942.00
44000200	DRIVE PAVEMENT REM	SQ YD	846	\$20.00	\$16,920.00
44000300	CURB REM	FOOT	502	\$11.00	\$5,522.00
44000600	SIDEWALK REM	SQ FT	2,586	\$3.00	\$7,758.00
44201690	CL D PATCH T1 4	SQ YD	18	\$1,000.00	\$18,000.00
44201692	CL D PATCH T2 4	SQ YD	126	\$325.00	\$40,950.00
44201694	CL D PATCH T3 4	SQ YD	22	\$890.00	\$19,580.00
56109210	WATER VALVES ADJUST	EACH	3	\$200.00	\$600.00
60255500	MAN ADJUST	EACH	2	\$500.00	\$1,000.00
60260100	INLETS ADJUST	EACH	1	\$500.00	\$500.00
60603800	COMB CC&G TB6.12	FOOT	854	\$53.50	\$45,689.00
60605000	COMB CC&G TY B-6.24	FOOT	119	\$55.00	\$6,545.00
67100100	MOBILIZATION	L SUM	1	\$8,600.00	\$8,600.00

Local Public Agency		County		Section Number		Route(s) (Street/Road Name)	
Village of Rantoul		Champaign		24-00118-00-SW		Pleasant Acres Sidewalk	
Item Number	Items	Unit	Quantity	Unit Price	Total		
78000400	THPL PVT MK LINE 6	FOOT	277	\$ 41.00	\$ 11,357.00		
Z0013798	CONSTRUCTION LAYOUT	L SUM	1	\$ 15,300.00	\$ 15,300.00		
K0026830	SHRUB REMOVAL	EACH	34	\$ 44.00	\$ 1,496.00		
X2020410	EARTH EXCAVATION SPL	CU YD	367	\$ 30.00	\$ 11,010.00		
X7010216	TRAF CONT & PROT SPL	L SUM	1	\$ 4,000.00	\$ 4,000.00		
X8440110	REL EX LP W/LUMINAIRE	EACH	1	\$ 1,300.00	\$ 1,300.00		
XX000001	LANDSCAPE SPL	L SUM	1	\$ 1,600.00	\$ 1,600.00		
XX000002	SEEDING CLASS 1 SPL	SQ YD	1,053	\$ 2.00	\$ 2,106.00		
XX000003	MULCH METHOD 1 SPL	SQ YD	1,053	\$ 2.00	\$ 2,106.00		
Bidder's Total Proposal						\$ 428,855.00	

1. Each pay item should have a unit price and a total price.
2. If no total price is shown or if there is a discrepancy between the product of the unit price multiplied by the quantity, the unit price shall govern.
3. If a unit price is omitted, the total price will be divided by the quantity in order to establish a unit price.
4. A bid may be declared unacceptable if neither a unit price or total price is shown.

**BOARD OF TRUSTEES  
VILLAGE OF RANTOUL**

**AGENDA ITEM**

ITEM: Items from Electric Department	DEPARTMENT: Administration
DATE: July 7, 2026	AMOUNT:
ATTACHMENTS:	ADMINISTRATIVE NOTES:
SUMMARY HIGHLIGHTS:	
RECOMMENDED ACTION:	
DEPARTMENT HEAD APPROVAL	VILLAGE ADMINISTRATOR

**BOARD OF TRUSTEES  
VILLAGE OF RANTOUL**

**AGENDA ITEM**

<p>ITEM: Purchase of Gas Meter Nodes for the Gas Division AMR/AMI Meter Project from Eaton Corporation in the amount of \$40,352.00, with a \$1,000.00 Contingency Fund</p>	<p>DEPARTMENT: Public Works</p>
<p>DATE: July 7, 2026</p>	<p>AMOUNT: \$40,352.00 - Nodes / Shipping \$1,000.00 - Contingency (2.55%) \$41,352.00 - Total</p>
<p>ATTACHMENTS:</p> <p>1. Eaton Gas Meter Nodes Quote</p>	<p>ADMINISTRATIVE NOTES:</p>
<p><b>SUMMARY HIGHLIGHTS:</b> This agenda item provides for the purchase of Nodes for gas meters in the amount of \$40,352.00 from Eaton Corporation for the update of the AMR/AMI Meter Project.</p> <p>It has been a goal of the Gas Department for several budget years to finalize the update of the Gas Meter inventory to Automatic Read. Since all of our meters are Eaton brand, this is the sole source vendor for the nodes, which communicate the readings from the system.</p> <p>A contingency fund of \$1,000.00 is requested since shipping is estimated at the time of the quote. Any unused money will remain in the budget line item.</p> <p>The purchase of the Gas Meter Notes are included in the Fiscal Year 2027 Gas Division Budget, Account 527-1127-430.75-40.</p>	
<p><b>RECOMMENDED ACTION:</b> Authorize the purchase of Gas Meter Nodes from Eaton Corporation in the amount of \$40,352.00 with a contingency of \$1,000.00.</p>	
<p>DEPARTMENT HEAD APPROVAL Chad Isley</p>	<p>VILLAGE ADMINISTRATOR Scott Eisenhauer</p>



Powering Business Worldwide

Cannon Technologies, Inc.  
3033 Campus Drive - Suite 350N  
Minneapolis, MN 55441  
Phone: (763)-595-7777  
Fax: (763)-543-7777

# Customer Quotation

Page 1 of 4

**Sold-to address**  
VILLAGE OF RANTOUL  
333 SOUTH TANNER  
RANTOUL IL 61866-2919  
US

**Ship-to address**  
VILLAGE OF RANTOUL  
GAS DIVISION-NINV  
200 WEST GROVE AVENUE  
RANTOUL IL 61866-2211  
US

**Incoterms:** Pre-Paid FOB PLANT  
**Payment Terms:** Net 30 Days

Quotation Number Date  
**24526895 06/24/2026**  
Cust. purchase order no. Cust. no.  
**06/24/2026 - JRS 714911**  
Prepared By  
**Jill Skarsten**  
Validity period  
**06/24/2026 to 07/24/2026**  
Sales Representative  
**900007328 / TOM THORSON**  
Customer Service Contact  
**JILL SKARSTEN Tele: 763-543-7685 Fax: 763-543-7777**

THIS DOCUMENT INCORPORATES AND IS SUBJECT TO THE ATTACHED TERMS AND CONDITIONS.

Item	Quantity	UOM	Description	Material No	Price	Ext. Value
<b>Cust.item Catalog Number</b>						
<b>Cust.Material Number</b>						
10	200	EA	RF Gas Module, Rockwell, Buffered LEAD TIME 26 WEEKS, ARO Commodity code 9026806000 200.000 Country of origin MINIMUM ORDER OF 200 PIECES REQUIRED	34201X42G44	194.00	38,800.00
<b>Product Subtotal</b>						<b>38,800.00</b>
<b>Cannon Frt Chg</b>						<b>1,552.00</b>
<b>Final amount in USD</b>						<b>40,352.00</b>

Freight charges are prepaid and billed at the quoted Rate. If shipment needs to be Expedited, higher freight charges will apply. Orders are accepted subject to Cooper Power Systems terms and conditions of sale which are included. Customer Contract Agreements with specific Terms and Conditions Override the standard Cooper Power Systems T&C's

06/24/2026  
09:49:27



Powering Business Worldwide

Cannon Technologies, Inc.  
3033 Campus Drive - Suite 350N  
Minneapolis, MN 55441  
Phone: (763)-595-7777  
Fax: (763)-543-7777

## Customer Quotation

Page 2 of 4

**Quotation no./Date**  
24526895 / 06/24/2026

**Sales Contact:** NATHAN LENHARDT /

## Terms and Conditions

### 1. Applicable Terms and Conditions

(a) These terms and conditions of sale establish the rights, obligations, and remedies of Buyer and Seller that apply to any order issued by Buyer for the purchase of Seller's products and/or services ("Products"). No additional or different terms or conditions, whether contained in Buyer's purchase order form or in any other document or communication pertaining to Buyer's order, will be binding on Seller unless accepted in writing by an authorized representative of Seller. Seller expressly objects to and rejects any additional or different terms and conditions, which shall be ineffective.

(b) If Seller's order acknowledgement, invoice, other document, or electronic transmittal including or attaching these terms and conditions is found to be an acceptance of an offer, acceptance is expressly made conditional upon Buyer's assent solely to these terms and conditions, and acceptance of any part of Products delivered by Seller shall be deemed to constitute such assent by Buyer. If the order acknowledgement, invoice, other document, or electronic transmittal including or attaching these terms and conditions constitutes an offer, Buyer's acceptance of the offer is hereby limited to the terms of the offer.

### 2. Price, Payment Terms, and Title

(a) All prices represent those in effect at the time of quotation and are subject to change without notice. Unless prices are bid or quoted as "firm," Seller reserves the right to invoice at prices in effect at the date of shipment, regardless of any prior bid and whether notice was received by Buyer. Unless otherwise indicated, prices are stated in United States dollars and are exclusive of shipping, handling, shipping insurance, duties, and sales, use, excise or similar taxes. Export packaging or any other special handling requested by Buyer will be at Buyer's expense. A service charge of \$25 will be assessed for any order less than \$250. Seller requires a minimum \$100 emergency handling charge for all orders that require shipment the same day or next day.

(b) Buyer acknowledges that the pricing of the Products has been set based on the agreed allocation of risks contained in these terms and conditions. If, notwithstanding the provisions of these terms and conditions, a court of competent jurisdiction determines that Buyer's terms and conditions apply to an order, then Seller shall have the right to either (i) modify the prices (including retroactively) according to the additional level of risk and responsibility that Buyer's terms and conditions require Seller to undertake; or (ii) cancel the order any time after such a determination without liability for the termination other than for the Products already delivered on these terms and conditions.

(c) Unless different credit terms have been extended to Buyer in writing by Seller, payment terms are net 30 days after delivery or date of invoice, whichever first occurs, in the currency invoiced. Seller reserves the right to modify or withdraw credit terms at any time without notice. If Buyer fails to fulfill the terms of payment, Seller may defer further shipments to Buyer or, at its option, cancel the unshipped portions of Buyer's orders. Buyer agrees to pay interest on all past due invoices at the lesser of 18% per annum, compounded monthly, or the highest contractual rate allowable under the law.

(d) Until full payment of all obligations of the Buyer for an order, Seller reserves the title (but not the risk of loss) to all Products furnished under that order. If the Buyer defaults in payment or performance or becomes subject to insolvency, receivership or bankruptcy proceedings or makes an assignment for the benefit of creditors, or without the consent of Seller voluntarily or involuntarily sells, transfers, leases or permits any lien or attachment on the Products, Seller may treat all amounts then or thereafter owing by Buyer to be immediately due and payable and Seller at its election may repossess Products for which Buyer has not paid in full. In the event of repossession of Products under this section or under the section entitled "Security Interest," Buyer agrees that Seller may enter the premises where the Products may be located and remove them without notice and without being liable to Buyer for such repossession. Buyer will not set off invoiced amounts or any portion thereof against sums that are due or may become due from Seller, its parents, affiliates, or subsidiaries. Buyer grants Seller a security interest in Products for which title has passed to Buyer, products in which Products are incorporated, and Products that Seller sells (including all Products acquired hereafter from Seller, and all accessions, substitutions, replacements, and additions, and any proceeds from sale or disposition of Products), as security for performance by Buyer of all of its payment obligations under these terms and conditions (including obligations regarding future advances). Buyer consents to Seller's execution of any documents to evidence and perfect this security interest, and agrees to execute the same if requested by Seller.

### 3. Delivery and Risk of Loss

(a) Unless otherwise agreed in writing, all deliveries of Products will be EXW (Incoterms 2000) Seller's facility. Products will be packed in Seller's standard commercial shipping packages. Charges for shipping may not reflect net transportation costs paid by Seller. Buyer shall reimburse Seller for all costs of storage and handling incurred by Seller after the date that Seller is prepared to make shipment.

(b) Delivery and shipping dates are approximate and represent Seller's best estimate of the time required to make delivery or shipment. Time is not of the essence with respect to the transactions covered by these terms and conditions, except with respect to Buyer's obligation to make all related

payments. Seller's obligations under these terms and conditions will be dependent upon Seller's ability to obtain necessary raw materials and components. Seller shall have the right to make partial deliveries and to ship up to forty (40) days in advance of shipping date.

### 4. Acceptance

Acceptance shall occur, if not before, when Buyer fails to reject within ten (10) days after delivery of the Products. Buyer may rightfully reject only when a reasonable inspection shows that the Products fail to conform substantially to the specifications for the Products. Buyer waives any right to revoke acceptance. Buyer's remedies for any nonconformity detected after acceptance are limited to those expressly provided in these terms and conditions for breach of warranty.

### 5. Limited Warranty

(a) Seller warrants to each original Buyer of Products that Products are, at the time of delivery to the Buyer, in good working order and conform to Seller's official published specifications, provided that no warranty is made with respect to any Products, component parts, or accessories manufactured by others but supplied by Seller.

(b) Seller's obligation under this warranty for any Product proved not to be as warranted within the applicable warranty period is limited to, at its option, replacing the Product, refunding the purchase price of the Product, or using reasonable efforts to repair the Product during normal business hours at any authorized service facility of Seller. All costs of transportation of any Product claimed not to be as warranted and of any repaired or replacement Product to or from such service facility shall be borne by Buyer.

(c) Seller may require the return of any Product claimed not to be as warranted to one of its facilities as designated by Seller, transportation prepaid by Buyer, to establish a claim under this warranty. The cost of labor for removing a Product and for installing a repaired or replacement Product shall be borne by Buyer. Replacement parts provided under the terms of this warranty are warranted for the remainder of the warranty period of the Products in which they are installed to the same extent as if such parts were original components. Warranty services provided under these terms and conditions do not assure uninterrupted operations of Products; Seller shall not be liable for damages caused by any delays involving warranty service.

(d) The warranty period for Products is the shorter of twelve (12) months from the date of installation or eighteen (18) months from the date of shipment unless otherwise agreed by Seller in writing.

(e) EXCEPT FOR THE EXPRESS WARRANTY SET FORTH ABOVE, SELLER PROVIDES PRODUCTS AS-IS AND MAKES NO OTHER REPRESENTATIONS OR WARRANTIES, EXPRESS OR IMPLIED, STATUTORY OR OTHERWISE, REGARDING THE PRODUCTS, THEIR FITNESS FOR ANY PARTICULAR PURPOSE, THEIR MERCHANTABILITY, THEIR QUALITY, THEIR NONINFRINGEMENT, OR OTHERWISE. IN NO EVENT SHALL SELLER BE LIABLE FOR THE COST OF PROCUREMENT OR INSTALLATION OF SUBSTITUTE GOODS.

### 6. LIMITATION OF LIABILITY

IN NO EVENT WILL SELLER BE LIABLE FOR ANY SPECIAL DAMAGES, CONSEQUENTIAL DAMAGES, INDIRECT DAMAGES, INCIDENTAL DAMAGES, STATUTORY DAMAGES, EXEMPLARY OR PUNITIVE DAMAGES, LOSS OF PROFITS, LOSS OF REVENUE, LIQUIDATED DAMAGES, OR LOSS OF USE, EVEN IF INFORMED OF THE POSSIBILITY OF SUCH DAMAGES. SELLER'S LIABILITY FOR DAMAGES ARISING OUT OF OR RELATED TO A PRODUCT SHALL IN NO CASE EXCEED THE PURCHASE PRICE OF THE PRODUCT FROM WHICH THE CLAIM ARISES. TO THE EXTENT PERMITTED BY APPLICABLE LAW, THESE LIMITATIONS AND EXCLUSIONS WILL APPLY WHETHER SELLER'S LIABILITY ARISES OR RESULTS FROM BREACH OF CONTRACT, BREACH OF WARRANTY, TORT (INCLUDING BUT NOT LIMITED TO NEGLIGENCE, GROSS NEGLIGENCE, MALICE, OR INTENTIONAL CONDUCT), STRICT LIABILITY, BY OPERATION OF LAW, OR OTHERWISE.

### 7. Cancellation and Return of Products

Orders shall not be subject to cancellation or modification either in whole or in part without Seller's written consent and then only with terms that will reimburse Seller for reasonable termination charges, including all progress billings and all incurred direct manufacturing costs. Seller's written consent must be given in advance of Buyer's return of Products for credit. Seller reserves the right to cancel any sale of Products without liability to Buyer (except for refund of monies already paid), if the manufacture or sale of the goods is or becomes technically or economically impractical.

### 8. Force Majeure

Seller shall not be liable for any failure to perform or delay in performing its obligations resulting directly or indirectly from or contributed to by any acts of God, acts of Buyer or those under Buyer's control, acts of government or other civil or military authorities, priorities, strikes, or other labor disputes, fires, accidents, floods, epidemics, war, riot, embargoes, delays in transportation, lack of or inability to obtain raw materials, components, labor, fuel or supplies, or other circumstances beyond Seller's reasonable control ("Force Majeure Event"). If Seller elects, the time for performance shall be extended by a period of time equal to the time lost because of any delays caused by reasons of a Force

## Terms and Conditions

Majeure Event. Should Seller be prevented from completing Buyer's order or any part thereof because of any Force Majeure Event, then Buyer agrees promptly upon request and upon receipt of invoice therefor, to pay Seller for any Product or Products then completed.

### 9. Work Product

"Work Product" shall include, without limitation, all designs, discoveries, creations, works, devices, masks, models, work in progress, service deliverables, inventions, products, special tooling, computer programs, procedures, improvements, developments, drawings, notes, documents, business processes, information and materials made, conceived or developed by Seller alone or with others that result from or relate to the Products. All Work Product shall at all times be and remain the sole and exclusive property of Seller. Buyer hereby agrees to irrevocably assign and transfer to Seller and does hereby assign and transfer to Seller all of its worldwide right, title and interest in and to the Work Product including all associated intellectual property rights. Buyer hereby waives any and all moral and other rights in any Work Product or any other intellectual property created, developed or acquired in respect of the Products. Seller will have the sole right to determine the treatment of any Work Product, including the right to keep it as trade secret, execute and file patent applications on it, to use and disclose it without prior patent application, to file registrations for copyright or trademark in its own name or to follow any other procedure that Seller deems appropriate. All tools and equipment supplied by Buyer to Seller shall remain the sole property of Seller.

### 10. Confidentiality

(a) Buyer may acquire knowledge of Seller Confidential Information (as defined below) in connection with Products and/or its performance hereunder and agrees to keep Seller Confidential Information in confidence during and following termination or expiration of this Agreement. "Seller Confidential Information" includes but is not limited to all information, whether written or oral, in any form, including, without limitation, information relating to the research, development, products, methods of manufacture, trade secrets, business plans, customers, vendors, finances, personnel data, Work Product, and other material or information considered proprietary by Seller relating to the current or anticipated business or affairs of Seller that is disclosed directly or indirectly to Buyer. In addition, Seller Confidential Information means any third party's proprietary or confidential information disclosed to Buyer in the course of providing Products to Buyer.

(b) Buyer agrees not to copy, alter or directly or indirectly disclose any Seller Confidential Information. Additionally, Buyer agrees to limit its internal distribution of Seller Confidential Information to Buyer's employees who have a need to know, and to take steps to ensure that the dissemination is so limited. In no event will Buyer use less than the degree of care and means that it uses to protect its own information of like kind, but in any event not less than reasonable care to prevent the unauthorized use of Seller Confidential Information. Buyer may disclose Seller Confidential Information that is required to be disclosed pursuant to a requirement of a government agency or law but only after Buyer provides prompt notice to Seller of such requirement and gives Seller the opportunity to challenge or limit the scope of the disclosure.

(c) Buyer further agrees not to use Seller Confidential Information except in the course of performing hereunder and will not use such Seller Confidential Information for its own benefit or for the benefit of any third party. All Seller Confidential Information is and shall remain the property of Seller. Upon Seller's written request, Buyer shall return, transfer or assign to Seller all Seller Confidential Information, including all Work Product, and all copies containing Seller Confidential Information.

### 11. Patent Indemnity

In the event any Product is made in accordance with drawings, samples or manufacturing specifications designated by Buyer, Buyer agrees to indemnify, defend, and hold Seller harmless from any and all damages, costs and expenses (including attorney's fees) relating to any claim arising from or relating to the design, distribution, manufacture, marketing, sale, or use of the Product or arising from or relating to a claim that such Product furnished to Buyer by Seller, or the use thereof, infringes any claim of any patent, foreign or domestic, and Buyer agrees at its own expense to undertake the defense of any suit against Seller brought upon such claim or claims.

### 12. Changes in Product Design or Manufacture

Seller shall have the right to change, discontinue or modify the design and construction of any of its products and to substitute material equal to or superior to that originally specified.

### 13. Software License

Software, if included with a Product, is hereby licensed and not sold. The license is nonexclusive, and is limited to use with the Product with which it is included. No other use is permitted and Seller retains for itself (or, if applicable, its suppliers) all title and ownership to any software delivered hereunder, all of which contains confidential and proprietary information and which ownership includes without limitation all rights in patents, copyrights, trademarks and trade secrets. Buyer shall not attempt any sale, transfer, sublicense, reverse compilation or disassembly (save to the extent expressly permitted by law) or redistribution of the software. Buyer shall not copy, disclose or display any such software, or otherwise make it available to others.

### 14. Compliance with Laws

Buyer shall comply with all laws and regulations applicable to Products including all applicable import and export laws and regulations. Buyer and Buyer's Agent shall provide all information requested by Seller relating to Seller's voluntary or mandatory compliance with any law or regulation, and Buyer shall indemnify Seller for any losses incurred by Seller arising from Buyer's or Buyer's Agent's failure to provide the information requested by Seller.

### 15. Waiver

No waiver of any provision of these terms and conditions (or any right or default hereunder) shall be effective unless in writing and signed by an authorized representative Seller. Any such waiver shall be effective only for the instance given, and shall not operate as a waiver with respect to any other rights or obligations under these terms and conditions or applicable law in connection with any other instances or circumstances.

### 16. Language

The parties have expressly required that these terms and conditions be prepared in the English language. Les parties aux présentes ont expressément exigé que les présents termes et les bons de commandes émis aux termes des présentes soient rédigés en langue Anglaise.

### 17. Choice of Law and Dispute Resolution

Except as set forth below, these terms and conditions shall be governed by and construed in accordance with the laws of the State of Texas, without reference to its choice of law rules. If both Seller and Buyer are incorporated under the laws of Canada or a province of Canada, these terms and conditions shall be governed by and construed in accordance with the laws of the Province of Ontario and the federal laws of Canada. If Buyer is incorporated in the United States, any claim or litigation arising out of or relating to Products shall be brought exclusively in a court of competent jurisdiction in Harris County, Texas. If Buyer is incorporated outside of the United States, any dispute will be resolved by arbitration in Houston, Texas, by three arbitrators and under the International Chamber of Commerce Rules of Arbitration. The language of the arbitration will be English. In all cases, Buyer and Seller expressly exclude from application the United Nations Convention on Contracts for the International Sale of Goods.

### 18. Assignment

Buyer may not assign, transfer or subcontract the performance of its services, or any of its rights and/or obligations hereunder, without Seller's prior written consent.

### 19. Severability

If any provision of these terms and conditions is determined to be illegal, invalid, or unenforceable, the validity and enforceability of the remaining provisions of these terms and conditions will not be affected and, in lieu of such illegal, invalid, or unenforceable provision, there will be added, as part of these terms and conditions, one or more provisions as similar in terms as may be legal, valid and enforceable under applicable law. CPS 04092020

### 20. Epidemic

Seller shall not be responsible for any failure to perform, or delay in performance of, its obligations resulting from the COVID-19 pandemic or any future epidemic, and Buyer shall not be entitled to any damages resulting therefrom.

**BOARD OF TRUSTEES  
VILLAGE OF RANTOUL**

**AGENDA ITEM**

<p>ITEM: Purchase of a Custom Utility Box for the Gas Division Vehicle from Knapheide Truck Equipment Center in the amount of \$63,876.00, with a \$1,000.00 Contingency Fund</p>	<p>DEPARTMENT: Public Works</p>
<p>DATE: July 7, 2026</p>	<p>AMOUNT: \$63,876.00 - Knapheide Truck Body \$1,000.00 - Contingency \$64,876.00 - Total</p>
<p>ATTACHMENTS:  1. Knapheide Utility Box Quote</p>	<p>ADMINISTRATIVE NOTES:</p>
<p><b>SUMMARY HIGHLIGHTS:</b> This Agenda item provides for the purchase of a new custom truck body for our new 2026 Ford F450 truck chassis in the PW Gas Division from Knapheide Truck Equipment Center in the amount of \$63,876.00. In April 2026, the board approved the purchase of the bare Ford F450 truck chassis. Delivery of the truck is expected in July 2026, and work on the body will begin upon delivery.</p> <p>A contingency of \$1,000.00 is requested should anything unforeseen arise or for extra lighting, fittings, or safety equipment. Any unused money will be returned to the budget.</p> <p>Construction and installation of the service truck body is included in the Fiscal Year 2027 Gas Division Budget, Account 527-1127-430.75-40.</p>	
<p><b>RECOMMENDED ACTION:</b> Authorize the purchase of a new custom truck body in the PW Gas Division from Knapheide Truck Equipment Center in the amount of \$63,876.00. A \$1,000.00 contingency fund is requested to address any other miscellaneous expense.</p>	
<p>DEPARTMENT HEAD APPROVAL Chad Isley</p>	<p>VILLAGE ADMINISTRATOR Scott Eisenhauer</p>



Seller: Knapheide Truck Equipment Center Quincy  
 2431 N 5TH STREET  
 PO BOX 290  
 QUINCY, IL 62306-0290  
 www.knapheide.com

QUOTE: QU-39-  
 1091280-6  
 Quote Expiration:  
 06/11/2026

**Contact(s): Danny Schwartz (Outside Sales)**  
 dschwartz@knapheide.com  
 2172579577

**Ali Norton (Inside Sales)**  
 anorton@knapheide.com  
 2175925448

**Ali Norton**  
 anorton@knapheide.com

**Customer: Rantoul Village Of**

**ID:** 60197  
**Address:** 200 W GROVE AVE  
 RANTOUL, IL 61866-2211

**Phone:** 2178926511  
**Contact:** Jay Schroeder  
**Contact Phone:** 2178413776  
**Email:** jayschroeder@myrantoul.com  
**End Customer:** Rantoul Village Of

**Terms:** NET 30 DAYS  
**Bid Spec:**

**Description:** Custom KC132H2094

**Quote Information:**

**Customer Request Date:** 05/14/2026  
**Quote Completed Date:** 06/16/2026  
**Date:** 06/16/2026 08:22 AM CDT  
**# of Units:** 1

**Delivery Information:**

**Total Price Includes F.O.B.:**  
**Ship Via:**  
**Ship To:** Rantoul Village Of  
 2178926511  
 200 W GROVE AVE  
 RANTOUL, IL 61866-2211

**Vehicle Information:**

**Make:** Ford  
**Chassis Type:** Chassis Cab  
**Rear Axle Type:** DRW  
**Fuel Type:** Gas  
**GVWR:** 16500

**Model:** F-450  
**Cab Type:** Regular  
**Drivetrain:** 4x4  
**Transmission Type:** Auto

**Year:** 2026  
**Cab to Axle:** 84  
**Engine Size:** 7.3  
**Wheelbase:** 169

Seq.	Description	Item	Quantity	Total
1	Custom body from Knapheide MFG State of IL pricing KC132H2094 Canopy Body  OVERALL LENGTH: ----- 133-1/4" OVERALL HEIGHT: ----- 90" OVERALL WIDTH: ----- 94"  Automotive Style Rivet-less Rotary Latches Automotive Door Seals Standard Shelving Package LED Surface Mount Lights with Rear Strobe Lights Activated Rear Access Door, Both Rear End Panels Factory Supplied Backup Camera Installed if sent from OEM Master Locking System Grab Handle Located at Right Rear K-coat Corrosion Protection with Knapheide's Exclusive 12-stage Electro-coating Prime Paint System Body Fully Undercoated Finish Painted White (Single Stage Enamel) Exterior, Cargo Area, and Compartment Interiors  KUV/KC Rear Doors w/Glass Includes punched window guards Ford 60"+CA Install Kit For use with wheel housing delete with 6" understructure. KC Upper Windows (4) KUV/KC Side Access Doors w/ 3pt NXG t-handle latches. Louver Vents-1pair (2) louvered vents in bulkhead KC Static Roof Vent Universal Fuel fill cup Harness For Rear Strobes For use to power rear strobes on chassis with factory upfitter switch.	PACKAGE	1.00	53,107.00



<p>****No Dome lights because of compressor****</p> <p>STREETSIDE (Left)  Ctech 6 Drawer Unit L1V 3-3", 2-5", 1-7"H Drawers with liners and no dividers.  28"W x 17.5"D x 29.8"H  18 Drawer Unit for LH 34"W X 12.12"D X 11"H overall dimensions  5.25"W X 2.75"H X 12.12"D drawers  CR Shelf Enclosure 132"LH Encloses area under top shelf.</p> <p>CURBSIDE (Right)  CR Shelf Enclosure 132"RH Encloses area under top shelf.  Ctech 6 Drawer Unit R1V 3-3", 2-5", 1-7"H Drawers with liners and no dividers.  28"W x 17.5"D x 29.8"H</p> <p>Tailshelf 94J N/ORTB 12K Hitch  7-Way flat Trailer wiring</p> <p>LED light bar on both front of canopy and above rear doors  add 2 flush mount strobes to each front side of canopy  6 flood lights - 2 each on side of body - 2 on front - and 2 at rear  2 front strobes (rear strobes are part of tail lights which will be activated)  LED compartment lights in all bins  5,000 watt inverter installed with aux battery- curbside upper canopy door  3 Hooks for Cargo area to hold a ladder---at time of order must specify location  Knapliner Cargo area--floor, compartment backs, &amp; half up front bulkhead</p>				
2	<p>Compressed Air Systems Compressor  CAS-C180GEH36HC-E</p> <p>22 HP HONDA ELECTRIC START, 35 CFM@175 PSI, 30 GAL HORZ, ELITE  (BELT GUARD COOLER, MTD BATTERY, AUTO TANK DRAIN, VIBRATION PADS,  6 GALLON FUEL CELL MOUNTED  ADD---40CFM@175PSI</p> <p>Installed in Cargo area  (body from Knapheide MFG will have venting on bulkhead)  Relocate Start switch in Driver's side 1st vertical compartment</p>	PACKAGE	1.00	10,769.00
<p><b>Total does not include any applicable taxes or transportation charges unless specifically noted herein:</b></p>				
			<b>Subtotal:</b>	<b>\$63,876.00</b>
			<b>Total:</b>	<b>\$63,876.00</b>

Customer PO

Total Price

**\*Credit Card Policy:** Knapheide accepts MasterCard, American Express, Visa and Discover cards for payment. Invoices greater than or equal to \$10,000 will include a 3% handling fee when paid by credit card beginning May 4, 2026.

**Liability for product on Knapheide property with terms Customer Pickup:** Product must be picked up within (14) days of notification of product available for customer pickup. Customer shall assume all responsibility for the Product, including but not limited to damage due to Acts of God or vandalism following 14 days of notification of product available for Customer pickup. Knapheide reserves the right to assess a storage fee of \$25/day for each day goods remain on Knapheide property beyond (14) days of notification of product available for Customer pickup.

**Cancellation Policy:** All cancellation requests must be made in writing. Upon any request for cancellation, any costs incurred by Knapheide during the fulfillment of Orders placed pursuant to this Quote shall be paid at 100%. Payments for cancellation are due in full at time of cancellation and/or upon cancellation of installation. Quoted prices are only guaranteed for orders placed as of the date specified on the Quote unless otherwise stated herein.

**Payment Policy:** Payment Terms are due upon receipt of signed quote unless prior credit agreement has been established at the time of order. Payment terms for customers with an established credit account will be Net 30 from date of invoice. Seller has right to assess late charges at 1.5% per month on all invoices that are 60 days or more past due.

**Pricing Policy:** All prices reflect the latest price in U.S. Dollars. Any order placed pursuant to this Quote shall be subject to these Terms and Conditions contained herein. These Conditions shall serve to exclude all other terms or conditions of purchase or other conflicting terms or conditions which may be issued, provided or referred to by Customer, all of which are hereby disclaimed or rejected, except insofar as any terms are expressly accepted in writing with an Authorized Knapheide Representative's written signature. Pricing quoted applies to chassis make/model originally provided and quantity quoted. Any deviation therefrom may result in price change. In addition, additional costs may be incurred in the process of fulfilling orders placed pursuant to this Quote and Knapheide reserves the right to adjust costs accordingly, including but not limited to, reprogramming fees, etc. Orders are subject to all

applicable state, local and federal excise taxes. Applicable taxes will be applied on final billing to customer upon completion of order. Seller must be in possession of the vehicle for this order within 90 days of quote acceptance or the order can be subject to price adjustments due to cost increases for materials, labor, and shop supplies.

**Return Policy:** All sales are final. Purchased parts or products are non-returnable.

---

By signing and accepting this quotation, Customer agrees to accept Knapheide Truck Equipment Center Quincy terms and conditions as stated above.

---

Customer Signature                      Print Name                      Title                      Date

---

Dealer Code                      Dealership                      Location

---

VIN                      If the chassis is customer supplied, Knapheide  
may require a chassis spec sheet

CHASSIS SHOWN FOR REPRESENTATION ONLY

ITEM NO.	QTY.	DESCRIPTION
1	1	WELD KC132H2094 SR W&GR
2	1	KIT FUEL FILL 21-42 KNAP

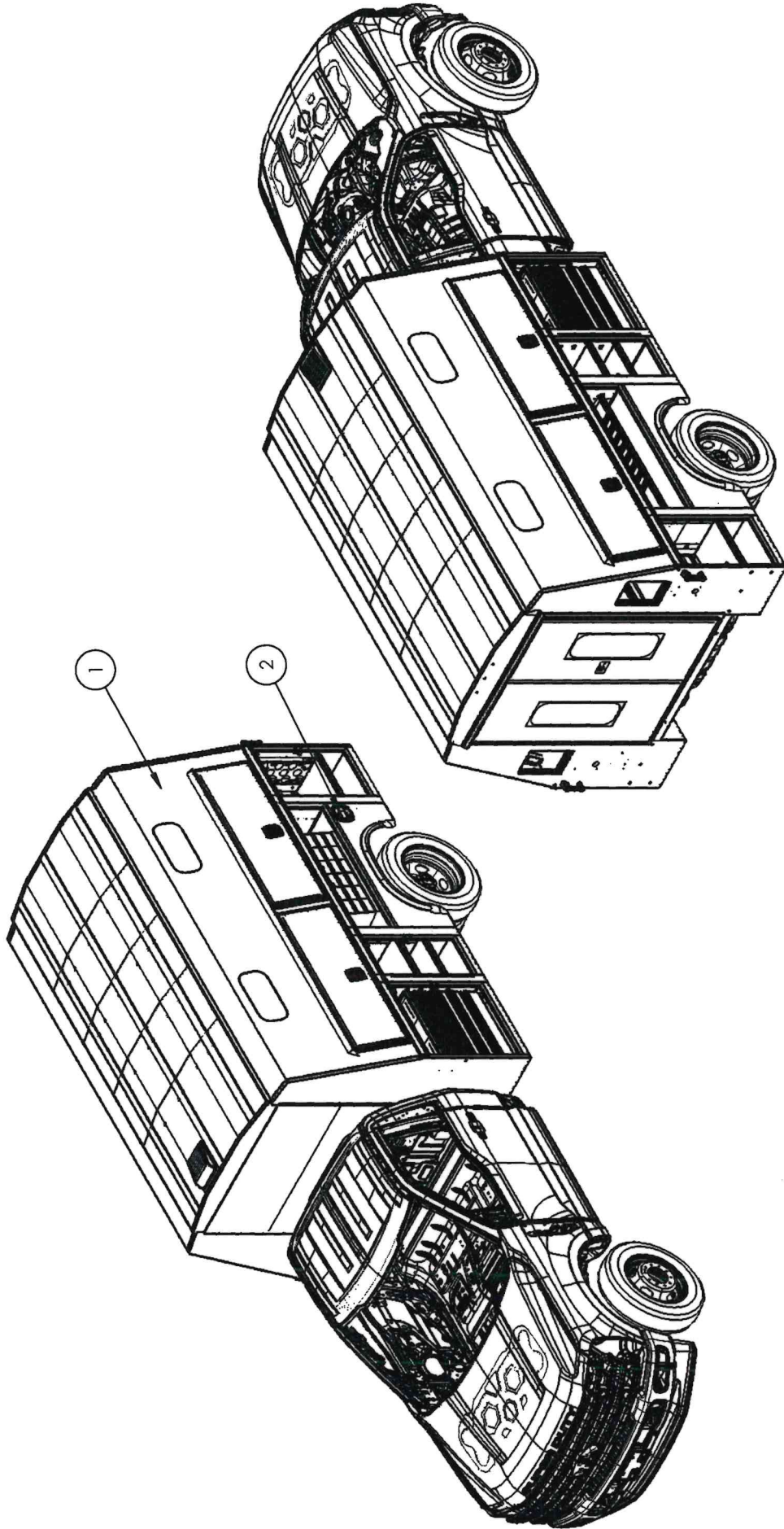

**VISUAL REPRESENTATION ONLY  
NOT AN APPROVAL DRAWING**

DRAWING TITLE: RANTOUL CITY OF IL C2791-26		CREATED BY: AGAIKWAD98	CREATED ON: 05/26/2026
DRAFTING TITLE: RANTOUL CITY OF IL C2791-26		SCALE: 1:45	SHEET: 1 OF 3
MATERIAL: KC132H2094		REFERENCE DRAWING: 1	REV: 1
WEIGHT: 3787.55 lbs		PART NUMBER: 36904301	ECO NO: 00001
<p>PROPERTY OF THE KNAPHEIDE MANUFACTURING COMPANY. ALL RIGHTS RESERVED. THIS DRAWING IS CONFIDENTIAL AND NOT TO BE REPRODUCED OR COPIED WITHOUT THE WRITTEN PERMISSION OF KNAPEIDE.</p> <p>UNLESS OTHERWISE SPECIFIED, THE FOLLOWING DIMENSIONS APPLY</p> <p>                 X: DECIMALS                  XX: FRACTIONS                  XXX: ANGLES                  0.12                  0.06                  30°             </p>			
<b>KNAPHEIDE</b> SINCE 1948			
1	00001	CHANGES DONE AS PER TICKET#2388364	05/26/2026
REV	ECO	CHANGE DESCRIPTION	DATE
<b>REVISION STATUS</b>			

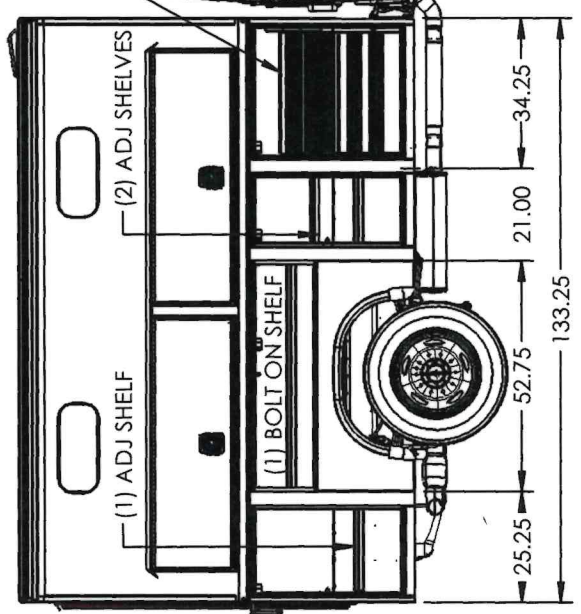
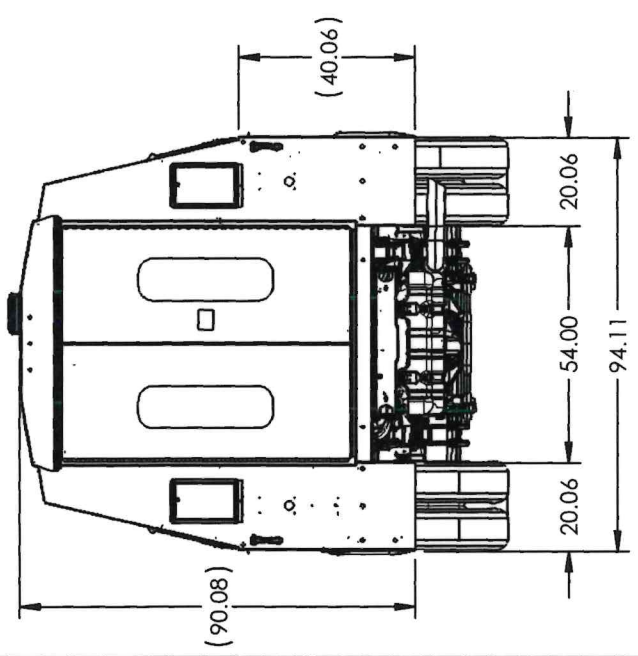

CTECH DRAWER UNIT INSTALLED

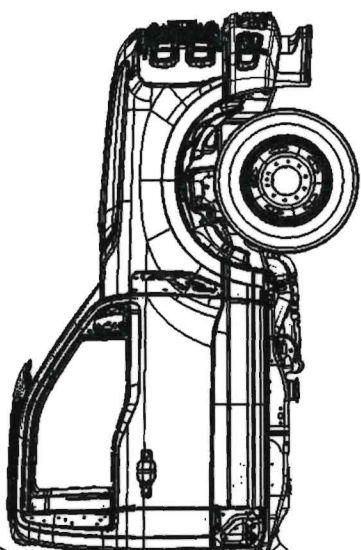

18 DRAWER UNIT INSTALLED

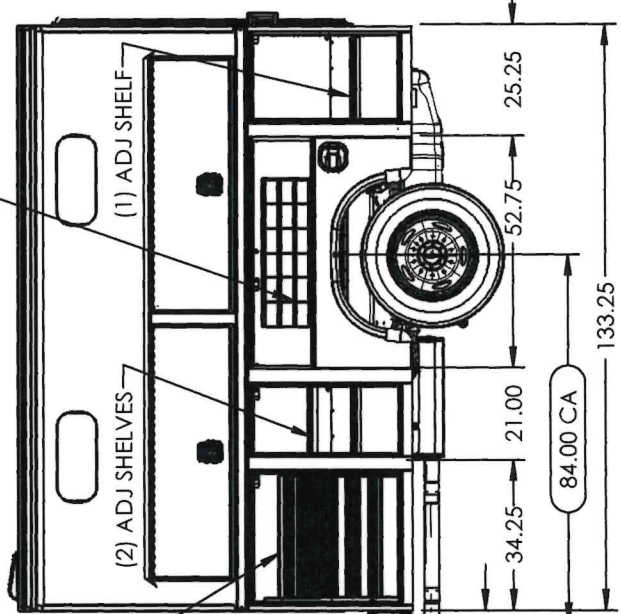

CTECH DRAWER UNIT INSTALLED

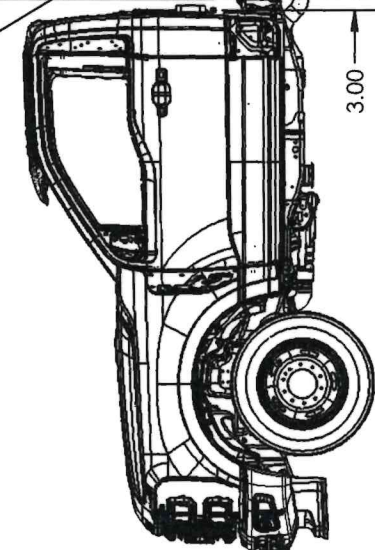

**VISUAL REPRESENTATION ONLY  
NOT AN APPROVAL DRAWING**

PROPERTY OF KNAAPHEIDE, INC. ALL RIGHTS RESERVED. QUANTITY AND TO BE LOANED TO THE RENTOR. SUBJECT TO RETURN TO KNAAPHEIDE, INC. WITHIN 30 DAYS. THIS DRAWING AND ANY PARTS THEREOF ARE NOT TO BE COPIED, REPRODUCED, OR TRANSMITTED IN ANY FORM OR BY ANY MEANS, ELECTRONIC OR MECHANICAL, INCLUDING PHOTOCOPYING, RECORDING, OR BY ANY INFORMATION STORAGE AND RETRIEVAL SYSTEM. FOR USE OF EXHIBITOR.	CREATED BY: AGAIKWAD78	CREATED ON: 05/26/2026
	SIZE: A	SCALE: 1:42
THE FOLLOWING TOLERANCES APPLY X: DECIMAL F: FRACTION .012 .005 .030 ANGLES ± .3°	REFERENCE DRAWING: KC132H2094	REV: 1
DRAWING TITLE: RANTOUL CITY OF IL C2791-26	PART NUMBER: 36904301	EGO NO.: 00001
MATERIAL: 304 SS	WEIGHT: 9787.55 lbs	



SHELF ENCLOSURE ON BOTH SIDES (LH AND RH)

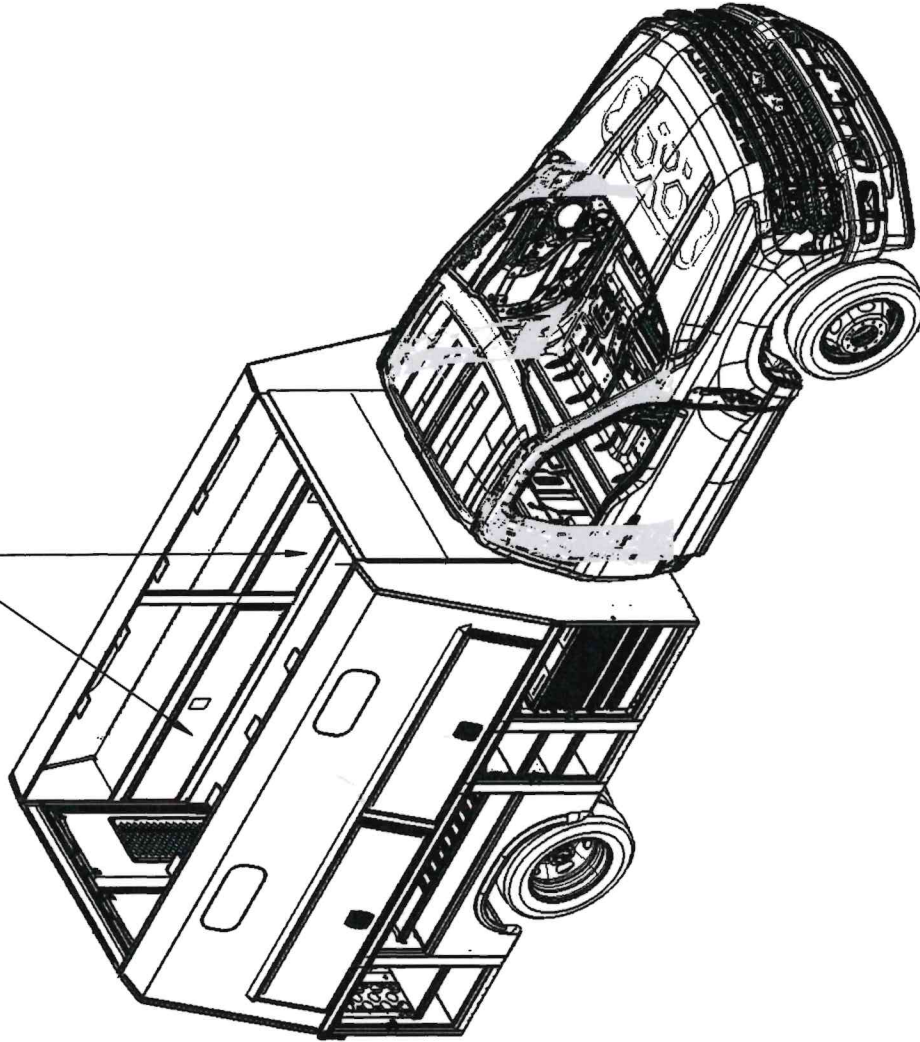

**VISUAL REPRESENTATION ONLY  
NOT AN APPROVAL DRAWING**

<p>PROPERTY OF THE MANUFACTURER OR SERVICE CONTRACTOR. THIS DRAWING IS LOANED TO THE RECIPIENT SUBJECT TO THE CONDITION THAT IT IS NOT TO BE REPRODUCED OR TRANSMITTED IN ANY FORM OR BY ANY MEANS, ELECTRONIC OR MECHANICAL, INCLUDING PHOTOCOPYING, RECORDING, OR BY ANY INFORMATION STORAGE AND RETRIEVAL SYSTEM, WITHOUT THE WRITTEN PERMISSION OF THE MANUFACTURER OR SERVICE CONTRACTOR.</p> <p>UNLESS OTHERWISE SPECIFIED, THE FOLLOWING TOLERANCES APPLY:</p> <p>X ± 0.12 XX ± 0.08 XXX ± 0.03 ANGLES ± 3°</p>	<p>CREATED BY: AGAIKWAD98</p> <p>SCALE: 1:42</p> <p>REFERENCE DRAWING:</p>	<p>CREATED ON: 05/26/2026</p> <p>SHEET: 3 OF 3</p> <p>REV: 1</p>
	<p>DRAWING TITLE: RANTOUL CITY OF IL C2791-26</p> <p>MATERIAL: KC132H2094</p> <p>WEIGHT: 3287.55 lbs</p>	<p>PART NUMBER: 36904301</p> <p>ECO NO: 00001</p>

**BOARD OF TRUSTEES  
VILLAGE OF RANTOUL**

**AGENDA ITEM**

<p>ITEM: Purchase of a Trailer-Mounted P2 DuraPatcher for the Street Systems Division from CMW Equipment in the amount of \$102,500.00, with a \$2,500.00 Contingency Fund</p>	<p>DEPARTMENT: Public Works</p>
<p>DATE: July 7, 2026</p>	<p>AMOUNT: \$102,500.00 - P2 DuraPatcher &amp; Freight <u>\$2,500.00 - Additional Items</u> \$105,000.00 - Total</p>
<p>ATTACHMENTS:</p> <p>1. CMW Equipment DuraPatcher P2 Quote</p>	<p>ADMINISTRATIVE NOTES:</p>
<p><b>SUMMARY HIGHLIGHTS:</b> This agenda item provides for the purchase of a new, trailer-mounted DuraPatcher P2 from CMW Equipment in the amount of \$102,500.00.</p> <p>On May 27, 2026, the Village observed a demonstration of this piece of equipment. After learning how to operate the machine and watching it in action, it was obvious to Staff that the DuraPatcher is a key piece of equipment for pavement preservation.</p> <p>A contingency fund of \$2,500.00 is requested as we will need to modify a truck to dump the aggregate into the machine and to add safety lighting to the trailer.</p> <p>Funding for the trailer-mounted DuraPatcher P2 will come out of Street Systems Division Fiscal Year 2027 Budget, Account 604-1175-430.75-40 (Machinery and Equipment). Funds will need to be transferred out of Account 604-1175-430.75-50 (Vehicles), which was budgeted for a Dump Truck and a Pickup Truck. One of those purchases will be delayed until the funds are available.</p>	
<p><b>RECOMMENDED ACTION:</b> Authorize the approval for the purchase of a new trailer mounted P2 DuraPatcher from CMW Equipment in the amount of \$102,500.00 with a contingency of \$2,500.00.</p>	
<p>DEPARTMENT HEAD APPROVAL</p>	<p>VILLAGE ADMINISTRATOR</p>



June 16, 2026



Mike Messlinger  
City of Rantoul, IL  
100 E. Flessner  
Rantoul, IL 61866

12890 Penridge Drive  
Bridgeton, MO 63044  
314-993-1336

Dear Mike,

We are pleased to quote the following for your consideration,

**ONE New DuraPatcher P2 Trailer Mounted Spray Patcher** with 74 HP John Deere Tier 4F diesel engine, 250 gallon emulsion tank with R15 insulation, (2) 1,500 watt electric tank heat pads, 3” drain valve, 5” temperature gauge, 450 CFM/10 PSI blower at 1500 RPM, 3-piece working boom designed for 18’ working radius, vent-flow nozzle to coat aggregate, 12 volt nozzle heater, dual axle trailer chassis with 6,000 lb axles, electric brakes, trailer lights, LED signal lights, beacon, truck end gate attachment, tool box, spare tire and all other standard equipment. Full factory warranty.

**Price** *job: Pearl, MS* **\$101,750.00**

**Freight from Factory to CMW Equipment** **\$750.00**

**Sourcewell Contract # 080521-CMW**

**Note** Requires field installation of truck tail gate assembly by customer.

**Terms** Net due 10 days from date of invoice. Subject to Sourcewell terms and conditions.

**Delivery** Approximately 2-3 Weeks.

All prices are current but subject to change.

All prices are plus any applicable taxes.

We thank you for the opportunity to quote the above equipment and look forward to being of service to you.

Sincerely,

CUMMINGS, MCGOWAN & WEST

Lee Newton  
Vice President



**INNOVATION  
IN PRESERVATION**

# P2

## Two-Person Patcher with DuraPatcher™ Technology



### A Permanent Patch in Four Easy Steps:

DuraPatcher™ Technology allows you to patch in almost any weather conditions and eliminate labor-intensive, poor performing patches. The DuraPatcher™ 4 step process is easy to learn and adapts to many different pavement applications.



**1. Clean:**  
Use high volume low pressure air to clean the patch of debris.



**2. Tack:**  
Prep the patch with a coating of emulsion.



**3. Fill:**  
Inject emulsion coated aggregate and fill pothole.



**4. Coat:**  
Apply a light coating of clean aggregate and open to traffic.

### Low Maintenance/Hi-Performance:

The DuraPatcher air-driven system utilizes virtually no moving parts in the delivery system. No augers, conveyors or other wear parts are required making it the most reliable in the industry. Aggregate is gravity fed from the tow vehicle completing the worry-free package. The system will deliver aggregate up to 2.5 inches in diameter without plugging or adjustment.

### Ergonomic No-Stress Boom:

The 3 piece boom design provides the ultimate in support for the operator moving the delivery hose. The boom/slide system easily moves throughout the entire 18-foot working radius allowing for smooth patching anywhere in the work zone.

### Vent-Flo Nozzle:

The specially designed Vent-Flo nozzle properly coats the aggregate with the right amount of emulsion regardless of aggregate size. The mix is applied at an angle to the repair allowing maximum placement and best operator safety. The vent holes diffuse/slow down the air stream to minimize rock over spray and maximize placement into the repair.

800-328-3874  
CIMLINE.COM



Vent-Flo™ Nozzle with Optional Heater



Gravity Feed Aggregate Delivery



High Visibility LED Safety Lights



Ergonomic No-stress Boom



Overnight Heating System

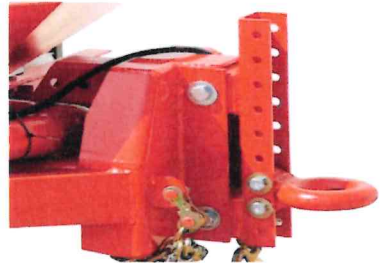

Hitch Adjusts for Height and Distance

## SPECIFICATIONS

### DuraPatcher™ P2 #301529

Emulsion Capacity	250 US Gallons
Aggregate Capacity	Up to 2.5" Maximum Diameter
Tank Gravity Drain	3 Inch with Brass Ball Valve
Tank Heating Method (Overnight)	Electric Blanket
Tank Heat Rating	2 x 1500w (110v @ 15a)
Tank Insulation	R15
Temperature Gauge	5 Inch
Engine	74HP Tier 4 Final Diesel
Fuel Capacity	18 Gallons
Clean-out Solvent Capacity	15 Gallons
Blower	450 CFM, 10 PSI @ 1500 RPM
Trailer Construction	2" x 6" x 1/4" rectangular tube
Trailer Brake Type	Electric
Dimensions (LxWxH)	194 x 96 x 91 Inches
Axles/Suspension	2x6000 Lbs. / Leaf Spring
Shipping Weight	5560 Lbs.
GVWR	10,400 Lbs.
Warranty	2 Year Limited

## PRODUCTS FROM CIMLINE



ME2 250 Gallon Mastic Melter Applicator



P5 One-Person Patcher with DuraPatcher™ Technology



T-Series Stationary Tanks

Due to continuous improvement, specifications are subject to change without notice.



Learn more at [cimline.com](http://cimline.com)  
Phone : 800-328-3874 Email : [orders@cimline.com](mailto:orders@cimline.com)

**BOARD OF TRUSTEES  
VILLAGE OF RANTOUL**

**AGENDA ITEM**

<p>ITEM: Services Agreement, Change Request #1 for the Line Design Engineering and Support for the Electric Department New Prospect Substation and Feeder Exits Project with BHMG Engineers, Inc. in the amount of \$12,100.00</p>	<p>DEPARTMENT: Public Works</p>
<p>DATE: July 7, 2026</p>	<p>AMOUNT: \$12,100.00</p>
<p>ATTACHMENTS:</p> <ol style="list-style-type: none"> <li>1. BHMG Engineers, Inc - Prospect Sub Feeder Exits - Change Request</li> </ol>	<p>ADMINISTRATIVE NOTES:</p>
<p><b>SUMMARY HIGHLIGHTS:</b>  This Agenda item provides for a Construction Engineering and Support Agreement, Change Request #1 with BHMG Engineers, Inc. in the amount of \$12,100.00 for the Electric Department Prospect Substation and Feeder Exits Project.</p> <p>The original agreement was approved by the board in July 2025 for the amount of \$263,000.00. The work, in addition to the original agreement, includes easement support, express line drawings, and express line material procurement.</p> <p>These additional Construction Engineering fees will be funded out of the Electric Department Bond Reserves.</p>	
<p><b>RECOMMENDED ACTION:</b> Authorize the approval for a construction engineering agreement change request #1 with BHMG engineers in the amount of \$12,100.00 to construct the new Prospect Substation and Feeder Exits project.</p>	
<p>DEPARTMENT HEAD APPROVAL Chad Isley</p>	<p>VILLAGE ADMINISTRATOR Scott Eisenhauer</p>



BHMG Engineers, Inc.

9735 Landmark Parkway Drive  
Suite 110A  
St. Louis, MO 63127

Scott Eisenhauer

June 29, 2026

Village Administrator

E: [scott.eisenhauer@bhm.com](mailto:scott.eisenhauer@bhm.com)

P: 308-760-1699

Ref: Project Change Request (PCR #1) for Prospect Substation Feeder Exits

Dear Scott Eisenhauer,

This project change request (PCR) is based on the additional scope and services outside of the original contract for the Prospect Substation Feeder Exits project. These services and scope additions are shown below:

- Easement Support
  - Coordination with Rantoul and Hanson
- Express Line
  - Drawing and BOM decoupling from standard IFB drawing set
  - Material & procurement support

Table 1 breaks down the current and revised project Fixed Fee contract amounts with the PCR#1 included.

Table 1: Consultant Design Cost Proposal

Description	Cost
Initial Proposal	\$ 263,000.00
PCR #1	\$ 12,100.00
<b>Fixed Feed / Lump Sum</b>	<b>\$ 275,100.00</b>

BHMG appreciates this opportunity to provide Rantoul with these services. Should any questions arise, please contact me at your convenience.

Sincerely,

**Chris Couch**  
Project Manager

**BOARD OF TRUSTEES  
VILLAGE OF RANTOUL**

AGENDA ITEM		PAGE	OF																		
<b>ITEM: Engineering Agreement with BHMG Engineers, Inc. for the Prospect Substation Upgrades</b>		<b>DEPARTMENT: Public Works</b>																			
<b>AGENDA SECTION:</b>		<b>PROJECT AMOUNT: \$263,000.00</b>																			
<b>ATTACHMENTS: (X) OTHER (See Summary Highlights) (X) SUPPORTING DOCUMENTS</b>		<b>DATE: June 28, 2025</b>																			
<p><b>SUMMARY HIGHLIGHTS:</b> This Agenda Item provides for an engineering agreement with BHMG Engineers, Inc. in the amount of \$263,000.00 for the line project design and engineering of the new Prospect Substation feeder entry and feeder exits. The feeder entry and exit lines are necessary to provide power to (69kV incoming feeds) and to distribute power out of (13.8kV outgoing feeds) the new substation. The new Prospect Substation is currently in the engineering and procurement stage and this project will be engineered and constructed in parallel with the substation project. To design, assist in procurement, and standard construction support for the proposed 69kv Prospect Substation Upgrades. Prospect Substation has required that all long lead time items be approved and ordered so when we start construction all items are here. We have already got board approvals for the transformers and switchgear. This agenda item is for the design and bid of the line feeders. Future Agenda will include the purchase of the line feeders.</p> <p><b>Prospect Substation Estimate of Cost:</b></p> <table border="0"> <tr> <td>\$2,347,422.00</td> <td>Switchgear</td> </tr> <tr> <td></td> <td>delivery Dec 1 2026</td> </tr> <tr> <td>\$5,896,930.50</td> <td>Transformers</td> </tr> <tr> <td></td> <td>delivery Aug 24 2026</td> </tr> <tr> <td>\$1,500,000.00</td> <td>Line Feeders</td> </tr> <tr> <td>\$1,260,400.00</td> <td>Engineering</td> </tr> <tr> <td>\$404,403.00</td> <td>Construction Eng</td> </tr> <tr> <td>\$5,604,219.50</td> <td>Construction</td> </tr> <tr> <td><b>\$17,013,375.00</b></td> <td><b>Total</b></td> </tr> </table> <p>The purchase was included in the FY26 reserves budget in line item #541-1180-430.75-70.</p>				\$2,347,422.00	Switchgear		delivery Dec 1 2026	\$5,896,930.50	Transformers		delivery Aug 24 2026	\$1,500,000.00	Line Feeders	\$1,260,400.00	Engineering	\$404,403.00	Construction Eng	\$5,604,219.50	Construction	<b>\$17,013,375.00</b>	<b>Total</b>
\$2,347,422.00	Switchgear																				
	delivery Dec 1 2026																				
\$5,896,930.50	Transformers																				
	delivery Aug 24 2026																				
\$1,500,000.00	Line Feeders																				
\$1,260,400.00	Engineering																				
\$404,403.00	Construction Eng																				
\$5,604,219.50	Construction																				
<b>\$17,013,375.00</b>	<b>Total</b>																				
<b>RECOMMENDED ACTION:</b> Authorize the approval for an engineering agreement with BHMG Engineers, Inc. in the amount of \$263,000.00 for the line project design and engineering of the new Prospect Substation feeder entry and feeder exits.																					
<b>DEPARTMENT HEAD APPROVAL:</b> Jacob D. McCoy, P.E.		<b>VILLAGE ADMINISTRATOR:</b> Scott Eisenhauer																			
<b>AGENDA PAGE NUMBER:</b>																					

**BOARD OF TRUSTEES  
VILLAGE OF RANTOUL**

**AGENDA ITEM**

<p>ITEM: Purchase of Express Line Materials for the Electric Department's Proposed New Prospect Substation Project with United Utility Supply in the amount of \$207,596.49, with a \$10,350.00 Contingency Fund</p>	<p>DEPARTMENT: Public Works</p>
<p>DATE: July 7, 2026</p>	<p>AMOUNT: \$207,596.49 - Various Components <u>\$ 10,350.00 - Contingency (5%)</u> \$217,946.49 - Total</p>
<p>ATTACHMENTS:</p> <ol style="list-style-type: none"> <li>BHMG Engineers, Inc - Prospect Sub Feeder Exits - Express Line Material</li> </ol>	<p>ADMINISTRATIVE NOTES:</p>
<p><b>SUMMARY HIGHLIGHTS:</b> This agenda item provides for the purchase of various materials (see attachments for a listing of materials) from United Utility Supply in the amount of \$207,596.49 for the express line and feeder exits for the New Prospect Substation.</p> <p>The Village received three competitive quotes for materials for this project. The quotes have been reviewed for completeness and the ability to meet specification requirements. Please see the attached Letter of Recommendation from BHMG Engineers, Inc. with a summary of the quotes for the purchase. The quote from United Utility Supply was the apparent low quote, and it did not include any noteworthy clarifications besides standard price escalators. United Utility Supply has a good list of completed reference projects. Their ability to quote all required materials and competitive pricing is why BHMG Engineers, Inc. recommends awarding the contract to United Utility Supply.</p> <p>Due to potential price escalators and potential design changes, we would advise a contingency fund of \$10,350.00.</p> <p>The purchase for these materials was included in the Electric Department Fiscal Year 2027 Reserves Budget.</p>	

RECOMMENDED ACTION: Authorize the purchase of various materials from United Utility Supply in the amount of \$207,596.49 for the proposed construction of the New Prospect Substation project with a contingency of \$10,350.00.

DEPARTMENT HEAD APPROVAL  
Chad Isley

VILLAGE ADMINISTRATOR  
Scott Eisenhauer



BHMG Engineers, Inc.

9735 Landmark Parkway Drive  
Suite 110A  
St. Louis, MO 63127

Chad Isley

June 29, 2026

Village of Rantoul  
E: CIsley@village.rantoul.il.us  
P: 217-892-6526

Ref: 3526 Prospect Substation Feeder Exits - Express Line Material

Dear Chad,

BHMG received quotes for the Prospect Substation Feeder Exits Express Line Material. A total of three (3) quotes were received and reviewed for completeness and ability to meet specification requirements. A summary of the quotes is provided below:

Contractor	Quote Price	Lead Time
United Utility Supply	\$207,596.49	Varies
Fletcher Reinhardt	\$236,670.29	Varies
Wesco	\$186,650.38	Varies

The quote submitted by United Utility Supply in the amount of \$207,596.49 met all specified requirements and included no major exceptions. Wesco does have a lower quote price, but they did not quote a lot of the material, so they will not be considered.

Based on United Utility Supply's ability to quote all required materials and competitive pricing, BHMG recommends awarding the Express Line Material purchase to United Utility Supply.

It is our understanding that the Village will issue a purchase order accordingly. Should you have any questions, please do not hesitate to contact us.

Sincerely,

Chris Couch  
Project Manager  
Enclosures: Bids

bhmg.com  
636.296.8600

DATE	BOM REV	PREPARE D BY	APPROVED BY	BILL OF EQUIPMENT & MATERIALS	NOTES	DESCRIPTION	Price	Ext. Price	Mfg (if quoted different than stated)	Part #	Lead Time	Std Pack		
3/26	0	MMK	REP	400 SHELLHOUSE DR. RANTOUL, IL 61866 3526 - NEW PROSPECT SUSTATION FEEDER EXITS	SUITABLE MANUFACTURER AND PART NUMBERS	ISSUED FOR PROCUREMENT - RANTOUL PURCHASED MATERIAL (EXPRESS LINE ONLY)								
ITEM NO.		ON BOM		ADDED	DESCRIPTION	MANUFACTURER	CATALOG OR STOCK NO.	REMARKS						
B130	0	3	EA		3M™ Mechanical Shearbolt Lug, QL2 Series, Two-Hole	3M	QL2-A-350-750		213.62	640.86				
B300	0	12	EA		Connector, Parallel Groove Clamp, #6-4/0 AWG, Bronze Alloy	Hubbell	ST4		31.26	375.12		3-4 weeks		
B306	0	18	EA		Connector, Clamp, 5/8" Ground Rod, #10 to #1 AWG Wire	Burndv	GRC58		2.42	43.56		10 weeks		
B308	0	18	EA		Grounding Clamp, CU Cable to Transformer Tank, Hex Wrench Shoulder, 1/2"-13 Thd., #6 Sol. - 250 MCM CU	Hubbell	GTCS41		31.89	574.02		2-3 weeks		
B616	0	4	EA		Connector, Clamp, Rod to Cable, Bronze Alloy, 1/2 to 3/4" Rod, 2/0 Sol. to 250 MCM Cu Cable	Hubbell	GC1112C3		71.20	284.80		2-3 weeks		
B617	0	84	EA		Connector, Compression, C-Tap, Copper, Main: 3/0 Str.-4/0 Str., Tap: 3/0 Str.-4/0 Str.	BURNDY	YC28C28		6.82	572.88		10 weeks		
B622	0	4	EA		Compression Connector, H-tap, 266-477 Main, 250-350 Tap	EATON	494-82		9.41	37.64	Blackburn	WR875	2-3 weeks	
12	0	12	EA		Compression Connector, H-tap, 250 kcmil-2 AWG	Burndv	YH2929		14.85	178.20		2-3 weeks		
B624	0	3	EA		Compression Connector, H-tap, 4/0-477 Main, #6-1 Tap	EATON	490-82		6.47	19.41	Blackburn	WR799	2-3 weeks	
C107	0	2	EA		Bolt, Machine, 5/8" x 14" w/ Square Nut	Hubbell	8814		2.62	5.24	Aluma-Form	AF8814	STK- 2weeks	
C203	0	2	EA		Locknut, 5/8", Concave MF	Hubbell	3512		0.25	0.50	Aluma-Form	AF8583	STK- 2weeks	
C301	0	2	EA		Washer, Spring, Formed Steel, 5/8", Hot Dip Galvanized	MacLean	J3540		2.50	5.00	Aluma-Form	AF3540	Ky Stk - 3 weeks	
C310	0	2	EA		Washer, Square, Flat, 11/16" Hole, 2" x 2" x 1/8"	Hubbell	6812		0.47	0.94	Aluma-Form	AF1074	2-3 weeks	
C311	0	2	EA		Washer, Square, Curved, 11/16" Hole, 2-1/4" x 2-1/4" x 3/16"	Hubbell	681012		0.89	1.78	Aluma-Form	AF6821	2-3 weeks	
C314	0	20	EA		Nail, Copperclad, 1/8" x 2-1/2" Length	Hubbell	T2050428		0.72	720.00		2-3 weeks		
C500	0	2	EA		Lag Screw, Galvanized, 1/2"x4", Fetter Drive	Hubbell	508754		0.53	1.06	Aluma-Form	AF8743P	2-3 weeks	
C504	0	50	EA		Lag Screw, Galvanized, 1/4" x 3", Gimlet Point	Hubbell	DF1L3		1.97	1970.00		2-3 weeks		
C800	0	4	EA		Cleat, Hold Down Bracket, 3"	Hubbell	EMHOTB1		9.71	38.84		3-4 weeks		
24	0	24	EA		1/2" Stainless Steel Washer	Burndv	LW14SS		0.51	51.00	Burndv	50FWSS	2-3 weeks	
C905	0	12	EA		1/2" Stainless Steel Hex Nut	Burndv	N14SS		1.85	22.20	Burndv	50HSSNBOX	2-3 weeks	
C906	0	12	EA		Bolt, 1/2"x1-1/2" Stainless Steel, 1 nut	Burndv	50X150HSSBUSA		3.61	43.32		4-6 weeks		
C907	0	12	EA		1/2" x 1.06 Belleville Washer, Stainless Steel	Burndv	50X106BWSS		2.05	24.60		2-3 weeks		
D102	0	30	FT		#6 AWG Wire, Copper, Solid, Soft Drawn, Bare	Southwire	106385		0.53	166.95	Nehring	3020060105	STK- 2weeks	
D109	0	30	FT		Wire, Conductor, 336MCM ACSR, "Merlin" (For Feeder Riser Pole Jumpers to Line)				3.42	7,113.60	CME	290800605	STK- 2weeks	
D118	0	90	FT		#2 Wire AWG, 7 Strand, Copper, Bare				1.39	172.36	Nehring	3020020705	STK- 2weeks	
D119	0	60	FT		4/0 AWG Copper, Bare, Soft Drawn, 7 STR				10.5	1,050	Nehring	407stradb	4-6 weeks	
D120	0	285	FT		#14 AWG Wire, Copper, Soft Drawn, Bare				0.13	65	Nehring	14soladb	4-6 weeks	
D402	0	11000	FT		Cable, 15kV, 1C 750Cu, 200mils (5.09mm), 133% insulation level, JCN, 13N	Rantoul Stock Cable		Stock Cable Rantoul has on hand						
D409	0	4200	FT		48ct. UG Fiber, All Dielectric, Polyethylene Jacket	AFL			0.67	13,400	AFL	LE0489C5101N1D	12-14 weeks	
E301	0	17	EA		5/8" x 8" Ground Rod, Copper plated	Hubbell	C615885		18.43	313.31	Galvan	6258G13	STK- 2weeks	
E302	0	4	EA		Ground Rod, 4" x 5/8"			Could this be cut in half to make 4ft	18.43	73.72	Galvan	6258G13	5	
E501	0	3	EA		Arrestor, 10kV Nominal, 8.4kV MCOV, Poly Housing, 10kA Discharge, Riser Class	Eaton	URS-1005-0A1A-		55.00	165.00	Aluma-Form	AHD-10B-10X-3X1-3X	4-6 weeks	
J200	0	1	EA		Fiberglass Foundation/Ground Sleeve for Switchgear	Nordic Fiberglass	GS-75-73-36-MG-		1,872.84	1,872.84	Nordic	GS-75-73-36-MG-67-62	14-16 weeks	
J204	0	9	EA		Junction Enclosure, Three-Phase, Steel, Green	Hoffman	UJ306623M2		1,373.67	12,363.03	Aluma-Form	ENC-SC3-306622-S2-G	6-8 weeks	
J205	0	27	EA		3-Phase Junction Bar Mounting Panel w/ One Parking Stand, Galvanized	Hoffman	UJ1P1G			0.00				
J206	0	9	EA		Ground Sleeve, for Junction Box	Nordic Fiberglass	GS-67-24-24M-MG-		789.05	7,101.45	Nordic	GS-67-24-24M-MG-60X14	14-16 weeks	
J207	0	27	EA		600A Deadbreak Junction Bar 15 kV Class, 4-Position, No Parking Stands	EATON	DJ625A4		470.45	12,702.15	Hubbell	625J4U	3-4 weeks	
147	0	1	AS, REQ'D		Crushed Stone, Clean									
149	0	1	AS, REQ'D		Concrete, 2500psi min. nom. compressive strength, 7-8" Slump, 3/8" maximum aggregate size									
K707	0	4	EA		17x30x24 Polymer Concrete Tier 22 Handhole Vault - For Fiber	JH American	APC173024PCT22		1,145.29	4,581.16	Hubbell	PG1730BA24 (box) & PG1730FH0009 (lid)	3-4 weeks	
K820	0	9	EA		Recon FI-3C underground fault indicator, 25 kA withstand, 0.8-2.6" range, IEEE 495 compliant	Smart Grid Solution	FI-3C S04BCX		206.52	1,858.68			6-8 weeks	
K838	0	3	EA		Remote fiber optic cable for FI-3C underground FCI, 3.1, 6 ft. long, includes hex fixing stud	Smart Grid Solution	FI-3C PH-HEX		57.65	172.95			6-8 weeks	
K841	0	9	EA		Cable trainer for FI-3C remote fiber optic cable, standard, without steel plate	Smart Grid Solution	FI-3C TI		15.55	139.95			6-8 weeks	
L208	0	1	EA		6" End Cap, PVC, 2-3/4" Length, 6-5/8" ID, 0.1875" thick	Plastic Supply	PVCCA06		30.18	301.80	Prime Conduit	CAP600	100	
L290	0	3	EA		U-Guard, 6" x 10", PV-Mold Nonmetallic, Flanged, Belled Ends	Carlton	59017N		84.65	253.95	Electrical Materials	PE6UG10	3-4 weeks	
L292	0	1	EA		Boot, Adapter, 6", PV-Mold Nonmetallic	Carlton	E939NRT		158.69	158.69	Prime Conduit		6-8 weeks	
L298	0	3000	FT		3" PVC Conduit, Sch. 40 PVC, w/ Bell End (10 or 20' Sticks), UoM in linear FT.	Carlton	49013-010	Can be substituted with other direct bury rated conduit	1.79	5,370.00	Prime Conduit		3-4 weeks	
L300	0	6000	FT		6" PVC Conduit, Sch. 40 PVC, w/ Bell End (10 or 20' Sticks), UoM in linear FT.	Carlton	49017-010	Can be substituted with other direct bury rated conduit	4.75	28,500.00	Prime Conduit		3-4 weeks	
L311	0	40	EA		Elbow, Galv. Conduit (GRC), 6", 90°, 60" Radius	ATKORE	876897		1,120.59	44,823.60			Made to Order, Non-returnable	
L340	0	900	FT		6" HDPE Conduit, Sch. 80, Smooth/Smooth, Black w/ Red Stripes, 1130 lb. Polyester Pull Tape, ETL Listed to UL 651	Carlton	U222C9N1A3KA450	6" SDR 13.5 HDPE Blk/red stripe	6.15	5,535.00	Dura-Line	10009863	6-8 weeks	
L341	0	700	FT		3" HDPE Conduit, Sch. 80, Smooth/Smooth, Black w/ Red Stripes, 1130 lb. Polyester Pull Tape, ETL Listed to UL 651	Carlton	U15C9N1A3KB1000	3" SDR 13.5 HDPE Blk/red stripe	2.45	7,380.00	Blue Diamond	BDJ14BK-RDS	6-8 weeks	
L359	0	38	EA		6" PVC Conduit Threaded Bushing				13.30	505.40	Prime Conduit	TA600	3-4 weeks	
L257	0	1	EA		Mounting bracket, 48in., 3-Phase Arrestor Cutout	ALUMA-FORM	R3CSA-48		469.50	469.50			1-2 weeks	
L291	0	3	EA		Backing Plate, 6", PV-Mold Nonmetallic	Carlton	591167		54.46	163.38	Prime Conduit	S9116	6-8 weeks	
L366	0	40	EA		6" Female Terminal Adaptor, Female Threaded to Female Smoothwall	ATKORE	FA60		14.85	1,485.00	Prime Conduit	FA600	3-4 weeks	
L368	0	2	EA		3" Female Terminal Adaptor, Female Smooth to Female Smoothwall	Carlton	E942L		4.25	425.00	Prime Conduit	CP300	3-4 weeks	
L369	0	4	EA		6" Female Terminal Adaptor, Female Smooth to Female Smoothwall	Carlton	E940R		12.74	1,274.00	Prime Conduit	CP600	100	
R402	0	1	EA		Switch Gear, Padmount, 15kV, 600A, 3-Phase 4-600A Positions, Manual, No SCADA	Federal Pacific	PSE-10	Proposed by Rantoul in 2025					100	
R405	0	3	EA		600A Deadbreak to 200A Loadbreak Bushing Insert, 15kV	RICHARDS	P615LRTP		189.28	567.84	Hubbell	615LRTPS	18-20 weeks	
R114	0	3	EA		15kV, Single Phase, 600A, 110kV BIL, Disconnect Switch	Hubbell	MBH66B		309.08	927.24	Hubbell	M3D66B	10 weeks	
S149	0	3	EA		Cable Grip, 750MCM Cable	Lewis Manufacturing	U162-SWB-PGE		25.43	76.29			3-4 weeks	
S148	0	3	EA		Hook Drive (J-Hook), Screw-In, 5/16" Dia.	Hubbell	DH516		0.80	2.40	Hubbell	PSC2050605	2-3 weeks	
U200	0	57	EA		600A Dead Break Elbow, w/ Cu Lug, Stud, & Insulating Plug	Eaton	TP615FF25TC	Must be verified to work with Rantoul stock 750Cu 15kV cable	539.75	30,765.75	TE Connectivity	ELB-15/28-610J-A2-CES2 ED9058-000	ELB	22-24 weeks
U400	0	54	EA		Insulating Cap for 600A Bushing w/ Drain Wire	Eaton-Cooper	DPC625		114.25	6,169.50	Hubbell	625IC	2-3 weeks	
U501	0	3	EA		Elbow Arrestor, Deadfront, 200A, 15kV, 10(8.4)kV MCOV, EPDM	Eaton	DAL215E8		142.55	427.65	Hubbell	215ELA10	STK- 2weeks	
U503	0	3	EA		Cold Shrink OT-III Termination Kit, Outdoor, 4-Skirt, 150kV BIL, JCN Cable, 15kV, 300-1000 MCM	3M	7655-S4		125.06	375.18	TE Connectivity	CSTO-283J EH7832-000	6-8 weeks	

\$207,596.49

## Terms and Conditions for the Sale of Goods

1. Applicability
2. Change Orders
3. Cancellations
4. Delivery of Goods
5. Title and Risk of Loss
6. Quantity
7. Inspection and Rejection of Nonconforming Goods
8. Returns and Refunds of Conforming Goods
9. Price
10. Payment Terms
11. Limited Warranty
12. Limitation of Liability
13. Indemnification
14. Compliance with Law
15. Termination
16. Waiver
17. Confidential Information
18. Force Majeure
19. Assignment
20. Relationship of the Parties
21. No Third-Party Beneficiaries
22. Governing Law
23. Submission to Jurisdiction
24. Notices
25. Severability
26. Survival
27. Amendment and Modification

### Applicability

(a) These terms and conditions of sale (these "Terms") are the only terms that govern the sale of the goods incorporated, a Kentucky corporation or Deco Supply Company, Inc., a Kentucky corporation doing business named on the applicable purchase order, confirmation of sale, or invoice, as applicable ("Buyer"). Notwithstanding any written contract signed by both parties is in existence covering the sale of the Goods covered hereby, the terms and conditions set forth herein shall prevail to the extent they are inconsistent with these Terms and acknowledge such inconsistencies.

(b) The Seller prepared quotation, confirmation of sale, or invoice, as applicable (the "Sales Confirmation") shall comprise the entire agreement between the parties and supersede all prior or contemporaneous understandings.

## Change Orders

- (a) Buyer may, by written instructions and/or drawings issued to Seller's sales representative (each a "Change Order") (email is acceptable). Any change requested by the Buyer to any aspect or the scope of an order must be approved in writing by Seller. Seller's approval of a Change Order does not constitute an agreement to accept the change.
- (b) Upon approval, Seller will use its best efforts to submit to Buyer a proposal for the Change Order, which includes the cost of materials, labor, and overhead. Seller will also provide to Buyer a list of suppliers and manufacturers relating to the relevant Sales Confirmation. If Buyer accepts such cost proposal, Buyer shall pay for the change order, subject to the cost proposal and the terms and conditions of this Agreement.

## Cancellations

- (a) Cancellations of the purchase of Goods held in stock by Seller ("Stock Goods") may be canceled only with the approval of Seller, given in Seller's sole discretion.
- (b) Seller will use reasonable efforts to approve the cancellations of Buyer's purchase of Goods not held in stock. To the extent Seller can cancel the order of Non-Stock Goods with the applicable vendor, Seller will provide notice of cancellation to Buyer. Any additional fees or charges incurred by Seller to cancel the order of Non-Stock Goods shall be charged to and payable by Buyer if no refund is applicable.
- (c) Seller will use reasonable efforts to approve the cancellations of Buyer's purchase of specialty manufactured Goods. To the extent Seller can cancel the order of specialty manufactured Goods with the applicable vendor, Seller will provide notice of acceptance of cancellation to Buyer. Any additional fees or charges incurred by Seller to cancel the order of specialty manufactured Goods shall be charged to and payable by Buyer if no refund is applicable.
- (d) All cancellations may be subject to a cancellation fee as determined by Seller in its sole discretion.

## Delivery of Goods

- (a) The Goods will be delivered within a reasonable time after the receipt of Buyer's purchase order. Seller shall notify Buyer of the date of delivery of the Goods in transit.
- (b) Unless otherwise agreed in writing by the parties, Seller shall deliver the Goods to the location indicated in the purchase order ("Delivery Point") using Seller's standard methods for packaging and shipping such Goods. Buyer shall take responsibility for the Goods within the number of days of Seller's written notice that the Goods have been delivered to the Delivery Point. Buyer shall be responsible for providing equipment and labor reasonably suited for receipt of the Goods at the Delivery Point, and will unload and store the Goods. Seller incurs no demurrage or other expense.
- (c) Seller may, in its sole discretion, without liability or penalty, make partial shipments of Goods to Buyer. Buyer shall pay for the units shipped whether such shipment is in whole or partial fulfillment of Buyer's purchase order.
- (d) If for any reason Buyer fails to accept delivery of any of the Goods on the date fixed pursuant to Seller's written notice, or if Seller is unable to deliver the Goods at the Delivery Point on such date because Buyer's equipment or labor is not available, Seller shall not be liable for the Goods.

## Title and Risk of Loss

Unless otherwise provided in the Sales Confirmation, Delivery of the Goods shall be made FOB shipping point. Buyer hereby grants to Seller a lien on and security interest in and to all of the Goods under the Sales Confirmation, wherever located, and whether now existing or hereafter arising or acquired from time to time, including replacements or modifications thereof, as well as all proceeds (including insurance proceeds) of the foregoing. This provision constitutes a purchase money security interest under the Kentucky Uniform Commercial Code.

## Quantity

If Seller delivers to Buyer a quantity of Goods of up to ten percent (10%) more or less than the quantity set forth in the Sales Confirmation, Buyer shall be entitled to object to or reject the Goods or any portion of them by reason of the surplus or shortfall and the Sales Confirmation adjusted pro rata.

## Inspection and Rejection of Nonconforming Goods

(a) Buyer shall inspect the Goods within three (3) business days of receipt ("Inspection Period"). Buyer will notify Seller in writing of any Nonconforming Goods during the Inspection Period and furnishes such written notice as required by Seller. "Nonconforming Goods" means only the following: (i) product shipped is different than product's label or packaging incorrectly identifies its contents.

(b) If Buyer timely notifies Seller of any Nonconforming Goods, Seller shall, in its sole discretion, (i) replace such Goods, or (ii) credit or refund the Price for such Nonconforming Goods, together with any reasonable shipping and handling charges in connection therewith. Buyer shall ship, at Seller's expense and risk of loss, the Nonconforming Goods to Seller. If Seller exercises its option to replace Nonconforming Goods, Seller shall, after receiving Buyer's written notice, ship the replaced Goods to the Delivery Point, at Seller's expense and risk of loss.

(c) Buyer acknowledges and agrees that the remedies set forth in Section 7(b) are Buyer's exclusive remedies. Except as provided under Section 7(b), all sales of Goods to Buyer are made on a one-way basis and Buyer shall be bound by this Agreement to Seller.

## Returns and Refunds of Conforming Goods

Subject to Seller's written approval, which shall be given in Seller's sole discretion, Seller will accept a return of Stock Goods for a refund of purchase price, less the original shipping and handling costs for, provided such return is made within sixty (60) days of receipt. Stock Goods must be in their original condition and unused. Approval of any Goods designated as Non-Stock Goods will be on a case-by-case basis and any final decision shall be made by Seller, in its sole discretion. To evaluate return options of Buyer's purchase of Non-Stock Goods or Goods that are specialty manufactured, if such return is approved, Seller will provide notice of acceptance of such return.

## Price

- (a) Unless otherwise noted as FIRM, Buyer shall purchase the Goods from Seller at the prices (the "Prices") of the Goods to a carrier for shipment to Buyer.
- (b) All Prices quoted are valid for thirty (30) days if the Good is a Stock Good, and for the applicable vendor'
- (c) Notwithstanding anything to the contrary in a separate agreement between the parties, Seller reserves event of any increase in tariffs, levies, duties, freight or importation cost or charges, supplier pricing or surc In such event, Seller will provide an updated quote or price and will not ship Product until Buyer receives a errors are not binding on Seller.
- (d) All Prices are exclusive of all sales, use, and excise taxes, and any other similar taxes, duties, and charges Authority on any amounts payable by Buyer. Buyer shall be responsible for all such charges, costs, and tax for any taxes imposed on, or with respect to, Seller's income, revenues, gross receipts, personal or real prop

## Payment Terms

- (a) Unless otherwise agreed by Buyer and Seller in writing which is signed by both parties, Buyer shall pay (30) calendar days from the date of Seller's invoice. Buyer shall make all payments hereunder in US dollars
- (b) Buyer shall pay interest on all late payments at the lesser of the rate of 1.5% per month or the highest ra daily and compounded monthly. Buyer shall reimburse Seller for all costs incurred in collecting any late pa fees. In addition to all other remedies available under these Terms or at law (which Seller does not waive b shall be entitled to suspend the delivery of any Goods and stop Goods in transit if Buyer fails to pay any arr continues for thirty (30) calendar days following written notice thereof.
- (c) Buyer shall not withhold payment of any amounts due and payable by reason of any set-off of any claim Seller's breach, bankruptcy, or otherwise.

## Limited Warranty

- (a) Seller is only a reseller of the Goods and shall transfer and assign to Buyer any and all transferable warra Goods. Unless otherwise specified in a writing signed by Seller, Seller provides no independent warranty fo for any alleged non- conforming part, defect, failure, inadequacy, or breach of any warranty related to Goo those warranties and remedies provided by the manufacturers or licensor thereof. Seller is not responsible uninstalling, installed Goods, delivering replacement Goods to the installation site, or installing replaceme Section 11 will be void unless Buyer provides Seller with notice of the Defect within thirty (30) calendar day: discovered the Defect. Buyer shall contact Seller prior to contacting the manufacturer or licensor. In the ev manufacturer or licensor, Buyer shall immediately notify and engage Seller on any and all discussions and **SELLER MAKES NO REPRESENTATIONS OR WARRANTIES WITH RESPECT TO ANY THIRD-PARTY PROE**

**(b) EXCEPT FOR THE WARRANTIES SET FORTH IN SECTION 11(b), SELLER MAKES NO WARRANTY WHATSOEVER INCLUDING ANY (a) WARRANTY OF MERCHANTABILITY; (b) WARRANTY OF FITNESS FOR A PARTICULAR PURPOSE; (c) WARRANTY AGAINST INFRINGEMENT OF INTELLECTUAL PROPERTY RIGHTS OF A THIRD PARTY; (d) WARRANTY OF DEALING, COURSE OF PERFORMANCE, USAGE OF TRADE, OR OTHERWISE.**

(c) The Seller shall not be liable for a breach of the warranties set forth in Section 11(b) unless: (i) Buyer gives notice of breach, in writing, to Seller within seven (7) calendar days of the time when Buyer discovers the breach; (ii) the defect is reasonably described, to Seller within seven (7) calendar days of the time when Buyer discovers the breach; (iii) Seller is given a reasonable opportunity after receiving the notice of breach of the warranty set forth in Section 11(b) to inspect the Goods; and Buyer (if requested to do so by Seller) returns such Goods to Seller's place of business at Seller's cost for inspection. Seller reasonably verifies Buyer's claim that the Goods are defective.

(d) The Seller shall not be liable for a breach of the warranty set forth in Section 11(b) if: (i) Buyer makes any claim for breach of the warranty set forth in Section 11(b) after the expiration of the time period for notice; (ii) the defect arises because Buyer failed to follow Seller's oral or written instructions as to the storage, handling, or maintenance of the Goods; or (iii) Buyer alters or repairs such Goods without the prior written consent of Seller.

**(e) THE REMEDIES SET FORTH IN SECTION 11(f) SHALL BE THE BUYER'S SOLE AND EXCLUSIVE REMEDY FOR ANY BREACH OF THE LIMITED WARRANTIES SET FORTH IN SECTION 11(b).**

## Limitation of Liability

**(a) IN NO EVENT SHALL SELLER BE LIABLE UNDER ANY THEORY OF LAW OR EQUITY TO BUYER OR ANY OTHER PARTY FOR ANY LOSS OF REVENUE OR PROFIT, OR FOR ANY CONSEQUENTIAL, INDIRECT, INCIDENTAL, SPECIAL, EXEMPLARY, OR PUNITIVE DAMAGES, INCLUDING REASONABLE ATTORNEY'S FEES, ARISING OUT OF OR RELATED TO BREACH OF CONTRACT, TORT (INCLUDING NEGLIGENCE), OR OTHERWISE, REGARDLESS OF WHETHER SUCH DAMAGES WERE FORESEEABLE AND WHETHER OR NOT SELLER HAS BEEN ADVISED OF THE POSSIBILITY OF SUCH DAMAGES. THIS LIMITATION OF LIABILITY SHALL APPLY TO ALL DAMAGES, INCLUDING REASONABLE ATTORNEY'S FEES, ARISING OUT OF OR RELATED TO BREACH OF CONTRACT, TORT (INCLUDING NEGLIGENCE), OR OTHERWISE, REGARDLESS OF WHETHER SUCH DAMAGES WERE FORESEEABLE AND WHETHER OR NOT SELLER HAS BEEN ADVISED OF THE POSSIBILITY OF SUCH DAMAGES. THIS LIMITATION OF LIABILITY SHALL APPLY TO ALL DAMAGES, INCLUDING REASONABLE ATTORNEY'S FEES, ARISING OUT OF OR RELATED TO BREACH OF CONTRACT, TORT (INCLUDING NEGLIGENCE), OR OTHERWISE, REGARDLESS OF WHETHER SUCH DAMAGES WERE FORESEEABLE AND WHETHER OR NOT SELLER HAS BEEN ADVISED OF THE POSSIBILITY OF SUCH DAMAGES.**

**(b) IN NO EVENT SHALL SELLER'S AGGREGATE LIABILITY ARISING OUT OF OR RELATED TO THIS AGREEMENT EXCEED THE AGGREGATE GROSS PRICE PAID BY BUYER FOR THE GOODS SOLD HEREUNDER.**

(c) The limitation of liability set forth in Section 12(b) shall not apply to (i) liability resulting from Seller's gross negligence or willful or wanton misconduct; (ii) liability resulting from Seller's death or bodily injury resulting from Seller's acts or omissions.

## Indemnification

Buyer shall indemnify, defend and hold harmless Seller, its affiliates, officers, directors, employees, agents and independent contractors from and against all claims, damages, losses, liability, cost, judgment, damages and expense, including attorneys' fees, which may be incurred by Seller or its affiliates, officers, directors, employees, agents and independent contractors as a result of demands by a third party arising out of or related to use of the Goods in any manner (e.g., solely or in combination with other Goods) in accordance with the applicable Terms or the applicable license agreement or specifications provided by the Goods manufacturer.

## Compliance with Law

requiring any government import clearance. Seller may terminate this Agreement if any governmental duties or any other duties or penalties on the Goods.

## Termination

In addition to any remedies that may be provided under these Terms, Seller may terminate this Agreement if Buyer, if Buyer: (a) fails to pay any amount when due under this Agreement and such failure continues for a period of 30 days after written notice of nonpayment; (b) has not otherwise performed or complied with any of these Terms, in violation of the terms of this Agreement; (c) files a petition for bankruptcy or commences or has commenced against it proceedings relating to bankruptcy, in violation of the terms of this Agreement; or (d) is insolvent, in violation of the terms of this Agreement, for the benefit of creditors.

## Waiver

No waiver by Seller of any of the provisions of this Agreement is effective unless explicitly set forth in writing. A partial exercise of any right, remedy, power, or privilege hereunder precludes any other or further exercise of that right, remedy, power, or privilege.

## Confidential Information

All non-public, confidential or proprietary information of Seller, including but not limited to, specifications, documents, data, business operations, customer lists, pricing, discounts, or rebates, disclosed by Seller to Buyer or accessed in written, electronic or other form or media, and whether or not marked, designated, or otherwise identified as confidential with this Agreement is confidential, solely for the use of performing this Agreement and may not be disclosed by Buyer to any third party without the prior written consent of Seller in writing. Upon Seller's request, Buyer shall promptly return all documents and other materials received from Seller in writing. Seller shall seek injunctive relief for any violation of this Section. This Section does not apply to information that is: (a) in the public domain at the time of disclosure; (b) confidentially obligations at the time of disclosure; or (c) rightfully obtained by Buyer on a non-confidential basis.

## Force Majeure

No party shall be liable or responsible to the other party, or be deemed to have defaulted under or breached this Agreement for failing to fulfill or perform any term of this Agreement (except for any obligations of Buyer to make payments) if such failure or delay is caused by or results from acts beyond the impacted party's ("Impacted Party") reasonable control following force majeure events ("Force Majeure Event(s)"): (a) acts of God; (b) flood, fire, earthquake, or explosion, whether declared or not; (c) terrorist threats or acts, riot or other civil unrest; (d) government order, law, or actions; (e) war, rebellion, or insurrection; (f) national or regional emergency; (g) telecommunication breakdowns, power outages, inadequate transportation services, or inability or delay in obtaining supplies of adequate quantities of goods beyond the reasonable control of the Impacted Party. The Impacted Party shall give notice within thirty (30) days to the other party, stating the period of time the occurrence is expected to continue. The Impacted Party shall

## Assignment

Buyer shall not assign any of its rights or delegate any of its obligations under this Agreement without the its sole discretion. Any purported assignment or delegation in violation of this Section is null and void. No : of its obligations under this Agreement.

## Relationship of the Parties

The relationship between the parties is that of independent contractors. Nothing contained in this Agree partnership, joint venture, or other form of joint enterprise, employment, or fiduciary relationship between authority to contract for or bind the other party in any manner whatsoever.

## No Third-Party Beneficiaries

This Agreement is for the sole benefit of the parties hereto and their respective successors and permitted is intended to or shall confer upon any other person or entity any legal or equitable right, benefit, or remec of these Terms.

## Governing Law

All matters arising out of or relating to this Agreement are governed by and construed in accordance with Kentucky without giving effect to any choice or conflict of law provision or rule (whether of the Commonw would cause the application of the laws of any jurisdiction other than those of the Commonwealth of Kent

## Submission to Jurisdiction

Any legal suit, action, or proceeding arising out of or relating to this Agreement shall be instituted in the fe the courts of the Commonwealth of Kentucky in each case located in the City of Louisville and County of Ji the exclusive jurisdiction of such courts in any such suit, action, or proceeding.

## Notices

All notices, requests, consents, claims, demands, waivers, and other communications hereunder (each, a " parties at the addresses set forth on the face of the Sales Confirmation or to such other address that may ) All Notices shall be delivered by personal delivery, nationally recognized overnight courier (with all fees pre

## Severability

If any term or provision of this Agreement is invalid, illegal, or unenforceable in any jurisdiction, such invalidity shall not affect the enforceability of any other term or provision of this Agreement or invalidate or render unenforceable such term or provision.

## Survival

Provisions of these Terms which by their nature should apply beyond their terms will remain in force after termination, including, but not limited to, the following provisions: Confidential Information, Governing Law, Submission of Disputes.

## Amendment and Modification

Seller reserves the right to modify these Terms from time to time without notice in Seller's sole direction, and such modifications shall be effective upon posting at <https://uus.coop/c/terms-and-conditions>.



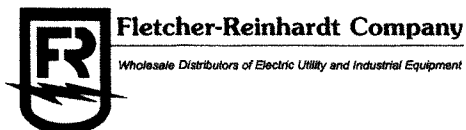

**Fletcher-Reinhardt Company**

*Wholesale Distributors of Electric Utility and Industrial Equipment*

FLETCHER-REINHARDT CO.  
 3105 CORPORATE EXCHANGE CT  
 BRIDGETON, MO 63044-3722  
 314-506-0700  
 Fax 314-506-0705



# Quotation

QUOTE DATE	QUOTE NUMBER
06/24/2026	S1368817
FLETCHER-REINHARDT CO. 3105 CORPORATE EXCHANGE CT BRIDGETON, MO 63044-3722 314-506-0700 Fax 314-506-0705	PAGE NO.  1 of 15

QUOTE TO:  
 RANTOUL VILLAGE  
 ACCOUNTS PAYABLE  
 333 S TANNER ST  
 RANTOUL, IL 61866-2919

SHIP TO:  
 RANTOUL, VILLAGE OF  
 WAREHOUSE / GPS COOR  
 621 COOK ST BLDG 729  
 RANTOUL, IL 61866

CUSTOMER NUMBER	CUSTOMER PO NUMBER	JOB NAME / RELEASE NUMBER	SALESPERSON	
4237	Express Line Material		Kris Thoele	
WRITER	SHIP VIA	TERMS	EXPIRE DATE	FREIGHT ALLOWED
Evan Price	F-R FRIDAY-1	Net 30 Days	07/23/2026	Yes
ORDER QTY	DESCRIPTION	UNIT PRICE	COMMENTS	
3ea	QL2-A-350-750 CONNECTOR- SHEARBOLT LUG, 350-750 MCM (AL/CU), UP TO 46kV APPLICATIONS, KIT INCLUDES LUG w/CENTERING RINGS, FOIL TAPE, COLD SHRINK SEALING TUBE, AND INSTALL INSTRUCTIONS 1.65"OD BARREL 3M *DS*	256.000/ea	3 WKS, B130	
12ea	ST-4 CONNECTOR- OH PARALLEL GROOVE 1 BOLT TYPE, BRONZE ALLOY, #6 SOL OR 6A TO 4/0 STR (MAIN & TAP), FOR CU/CW/GS, CONDUCTOR RANGE (MAIN & TAP) 0.162"-0.562" HUBBELL/ANDERSON (30/CTN) *DS*	18.000/ea	STK, B300	
18ea	GRC-58 CLAMP, GROUND ROD, CU ALLOY, FOR 5/8" COPPER CLAD ROD w3/8"HEX BOLT, #12 AWG STR-#1 AWG STR, UL/RUS LISTED, MOQ=1 (100/CTN) 258351, BURNDY *DS*	4.500/ea	STK, B306	

\*\* Continued on Next Page \*

Subtotal	
S&H Charges	
Tax	
Amount Due	

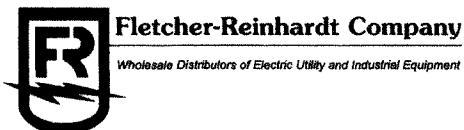

**Fletcher-Reinhardt Company**

Wholesale Distributors of Electric Utility and Industrial Equipment

FLETCHER-REINHARDT CO.  
3105 CORPORATE EXCHANGE CT  
BRIDGETON, MO 63044-3722  
314-506-0700  
Fax 314-506-0705



# Quotation

QUOTE DATE	QUOTE NUMBER
06/24/2026	S1368817
FLETCHER-REINHARDT CO. 3105 CORPORATE EXCHANGE CT BRIDGETON, MO 63044-3722 314-506-0700 Fax 314-506-0705	PAGE NO.
	2 of 15

QUOTE TO:  
RANTOUL VILLAGE  
ACCOUNTS PAYABLE  
333 S TANNER ST  
RANTOUL, IL 61866-2919

SHIP TO:  
RANTOUL, VILLAGE OF  
WAREHOUSE / GPS COOR  
621 COOK ST BLDG 729  
RANTOUL, IL 61866

CUSTOMER NUMBER	CUSTOMER PO NUMBER	JOB NAME / RELEASE NUMBER	SALESPERSON	
4237	Express Line Material		Kris Thoele	
WRITER	SHIP VIA	TERMS	EXPIRE DATE	FREIGHT ALLOWED
Evan Price	F-R FRIDAY-1	Net 30 Days	07/23/2026	Yes
ORDER QTY	DESCRIPTION	UNIT PRICE	COMMENTS	
18ea	GTCS41 BRONZE TRANSFORMER, TANK GROUND CLAMP, WIRE RANGE: #6 SOL -250MCM, *PURCHASING NOTE MOQ=50EA STD PKG ONLY (50/CTN) HPS *DS*	19.000/ea	STK, B308	
100ea	YC28C28 CONNECTOR- COPPER COMPR (CRIMP) C-TAP, 3/0 STR-4/0 STR CU (MAIN & TAP) DIE INDEX: U-F OR U-D3 (F OR D3) BURNDY (MOQ=1, 50/CTN)	9.750/ea	3 WKS, B617	
25ea	^494-82 Compression Connector, H-tap, 266-477 Main, 250-350 Tap EATON	13.000/ea	14 WKS, B622	
50ea	SHIPPING MEMO YH2929 CONNECTOR- CU COMPRESSION H-TAP, TINNED, COND. RANGE: #2-250 MCM (MAIN), #2-4/0 (TAP) BURNDY (MOQ=1)(50/CTN)	17.500/ea	2 WKS, B623	
** Continued on Next Page *		Subtotal		
		S&H Charges		
		Tax		
		Amount Due		



**Fletcher-Reinhardt Company**

Wholesale Distributors of Electric Utility and Industrial Equipment

FLETCHER-REINHARDT CO.  
 3105 CORPORATE EXCHANGE CT  
 BRIDGETON, MO 63044-3722  
 314-506-0700  
 Fax 314-506-0705



**Quotation**

QUOTE DATE	QUOTE NUMBER
06/24/2026	S1368817
FLETCHER-REINHARDT CO. 3105 CORPORATE EXCHANGE CT BRIDGETON, MO 63044-3722 314-506-0700 Fax 314-506-0705	PAGE NO.
	3 of 15

QUOTE TO:  
 RANTOUL VILLAGE  
 ACCOUNTS PAYABLE  
 333 S TANNER ST  
 RANTOUL, IL 61866-2919

SHIP TO:  
 RANTOUL, VILLAGE OF  
 WAREHOUSE / GPS COOR  
 621 COOK ST BLDG 729  
 RANTOUL, IL 61866

CUSTOMER NUMBER	CUSTOMER PO NUMBER	JOB NAME / RELEASE NUMBER	SALESPERSON	
4237	Express Line Material		Kris Thoele	
WRITER	SHIP VIA	TERMS	EXPIRE DATE	FREIGHT ALLOWED
Evan Price	F-R FRIDAY-1	Net 30 Days	07/23/2026	Yes
ORDER QTY	DESCRIPTION		UNIT PRICE	COMMENTS
3ea	WR-815 CONNECTOR - TAP, COMPR, PG, AA, 4/0-477 ACSR MAIN, #6SOL-2/0STR TAP, AL/CU, W/INHIBITOR, TYPE "N" DIE (10/BX-80/CS) ABB/BKB		7.000/ea	STK, B624
2ea	8814 BOLT, MACH 5/8" X 14" WITH SQUARE NUT * (J8814)(30/CTN) (1800/pallet) *DS*		4.750/ea	STK, C107
2ea	3512 LOCKNUT- MF, STEEL, 5/8" SQUARE HUBBELL/CHANCE (J8583)(1000/CTN)		1.500/ea	STK, C203
50ea	3540 WASHER, SPRING CLIP, STEEL, GALV. (ASTM A153), 11/16" HOLE FOR 5/8" BOLT, RUS LISTED HUBBELL/CHANCE (50/CTN) (J3540) *DS*		5.250/ea	STK, C301
2ea	6812 WASHER, SQUARE, 2" X 2" X 1/8" FOR 5/8" BOLT (11/16" HOLE) (J1074), HPS (300/CTN) *DS*		1.500/ea	3 WKS, C310
** Continued on Next Page *			Subtotal	
			S&H Charges	
			Tax	
			Amount Due	

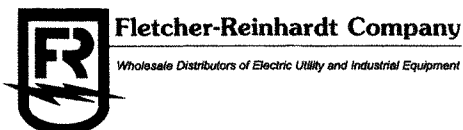

**Fletcher-Reinhardt Company**

Wholesale Distributors of Electric Utility and Industrial Equipment

FLETCHER-REINHARDT CO.  
 3105 CORPORATE EXCHANGE CT  
 BRIDGETON, MO 63044-3722  
 314-506-0700  
 Fax 314-506-0705



# Quotation

QUOTE DATE	QUOTE NUMBER
06/24/2026	S1368817
FLETCHER-REINHARDT CO. 3105 CORPORATE EXCHANGE CT BRIDGETON, MO 63044-3722 314-506-0700 Fax 314-506-0705	PAGE NO.  4 of 15

QUOTE TO:  
 RANTOUL VILLAGE  
 ACCOUNTS PAYABLE  
 333 S TANNER ST  
 RANTOUL, IL 61866-2919

SHIP TO:  
 RANTOUL, VILLAGE OF  
 WAREHOUSE / GPS COOR  
 621 COOK ST BLDG 729  
 RANTOUL, IL 61866

CUSTOMER NUMBER	CUSTOMER PO NUMBER	JOB NAME / RELEASE NUMBER	SALESPERSON	
4237	Express Line Material		Kris Thoele	
WRITER	SHIP VIA	TERMS	EXPIRE DATE	FREIGHT ALLOWED
Evan Price	F-R FRIDAY-1	Net 30 Days	07/23/2026	Yes
ORDER QTY	DESCRIPTION	UNIT PRICE	COMMENTS	
200ea	6810-1/2 WASHER, SQUARE CURVED, 2-1/4" 5/8" BOLT (J6821) *STD PKG ONLY* (200/CTN) HPS	2.500/ea	4 WKS, C311	
1000ea	T2050428 NAIL, COPPERCLAD, SIZE 3D, 2.5"L, USED w/T2050429 GROUND WIRE CLIP, MOQ=1000 (STD PKG ONLY: 1000/CTN), HPS *DS*	1.000/ea	6 WKS, C314	
2ea	PSC2050591 SCREW- LAG, 1/2 IN, GIMLET THREAD, 4 IN LONG, HEX HEAD, HDG STEEL HUBBELL/CHANCE (200/CTN) * Sub for: 508754 SCREW- LAG, 1/2" X	3.250/ea	STK, C500	
1000ea	DF1L3 SCREW- LAG, 1/4" X 3" GIMLET POINT (3/8" SQ HEAD) 2" THREAD LENGTH (J8723) HUBBELL/CHANCE (1000/CTN) *DS*	1.000/ea	5 WKS, C504	
4ea	EMHOTB1 HOLD DOWN BRACKETS 3"L X 1.5"W X 1/4"THICKNESS	13.500/ea	2 WKS, C800	
** Continued on Next Page *		Subtotal		
		S&H Charges		
		Tax		
		Amount Due		



**Fletcher-Reinhardt Company**

Wholesale Distributors of Electric Utility and Industrial Equipment

FLETCHER-REINHARDT CO.  
 3105 CORPORATE EXCHANGE CT  
 BRIDGETON, MO 63044-3722  
 314-506-0700  
 Fax 314-506-0705



**Quotation**

QUOTE DATE	QUOTE NUMBER
06/24/2026	S1368817
FLETCHER-REINHARDT CO. 3105 CORPORATE EXCHANGE CT BRIDGETON, MO 63044-3722 314-506-0700 Fax 314-506-0705	PAGE NO.  5 of 15

QUOTE TO:  
 RANTOUL VILLAGE  
 ACCOUNTS PAYABLE  
 333 S TANNER ST  
 RANTOUL, IL 61866-2919

SHIP TO:  
 RANTOUL, VILLAGE OF  
 WAREHOUSE / GPS COOR  
 621 COOK ST BLDG 729  
 RANTOUL, IL 61866

CUSTOMER NUMBER	CUSTOMER PO NUMBER	JOB NAME / RELEASE NUMBER	SALESPERSON	
4237	Express Line Material		Kris Thoele	
WRITER	SHIP VIA	TERMS	EXPIRE DATE	FREIGHT ALLOWED
Evan Price	F-R FRIDAY-1	Net 30 Days	07/23/2026	Yes
ORDER QTY	DESCRIPTION	UNIT PRICE	COMMENTS	
12ea	23-69-014 SCREW, CAP, HEX, 1/2" X 1-1/2" COMPLETE ASSY (JPR-4651) MATERIAL: BOLT 304 SS, WITH (1) AISI ALLOY 301 SS BELLEVILLE WASHER, (2) AISI ALLOY 316 SS FLAT WASHERS,(1) AISI ALLOY 316 SS HEX NUT (ASM-4076/23-69-014)	3.500/ea	STK, C904-907	
25lb	#6 7STR CU BARE SD - LB COPPER ON 25# SPOOLS (315'/SPL) STRANDED	8.500/lb	3 WKS, D102	
30ft	^MERLIN-FT CONDUCTOR, BARE, 336.4 KCMIL ACSR 18/1 STRAND, OD: 0.684", 8680# RATED STRENGTH, METAL WGTS/MFT: AL=315.8 Lbs; STEEL=49.5 LBS	7.500/ft	2 WKS, D109	
25lb	----- 1 x 30' COIL #2 SOL SD BARE CU 25# SPOOL (125'/SPOOL) SOLD PER POUND ONLY	9.500/lb	STK, D118	
** Continued on Next Page *		Subtotal		
		S&H Charges		
		Tax		
		Amount Due		

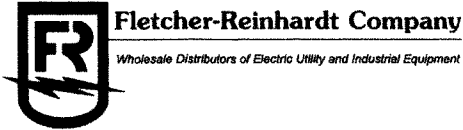

FLETCHER-REINHARDT CO.  
 3105 CORPORATE EXCHANGE CT  
 BRIDGETON, MO 63044-3722  
 314-506-0700  
 Fax 314-506-0705



# Quotation

QUOTE DATE	QUOTE NUMBER
06/24/2026	S1368817
FLETCHER-REINHARDT CO. 3105 CORPORATE EXCHANGE CT BRIDGETON, MO 63044-3722 314-506-0700 Fax 314-506-0705	PAGE NO.  6 of 15

QUOTE TO:  
 RANTOUL VILLAGE  
 ACCOUNTS PAYABLE  
 333 S TANNER ST  
 RANTOUL, IL 61866-2919

SHIP TO:  
 RANTOUL, VILLAGE OF  
 WAREHOUSE / GPS COOR  
 621 COOK ST BLDG 729  
 RANTOUL, IL 61866

CUSTOMER NUMBER	CUSTOMER PO NUMBER	JOB NAME / RELEASE NUMBER	SALESPERSON	
4237	Express Line Material		Kris Thoele	
WRITER	SHIP VIA	TERMS	EXPIRE DATE	FREIGHT ALLOWED
Evan Price	F-R FRIDAY-1	Net 30 Days	07/23/2026	Yes
ORDER QTY	DESCRIPTION	UNIT PRICE	COMMENTS	
500ft	4/0 19STR SD BARE CU WIRE- 4/0 19 STRANDED BARE COPPER SOFT DRAWN ON 500' NR REEL 518#/MFT (APPROX 259# NET PER 500' SPOOL)	8.000/ft	STK, D119	
285ft	^14-SOL-SD-BARE-CU-FT WIRE- 14 GAUGE SOL SOFT DRAWN COPPER BARE	0.800/ft	3 WKS, D120	
20000ft	----- 1 x 285' REEL ^LE0489C5101N1D LE-Series: Loose Tube Gel Free Cable - Single Jacket, Black jacket color, 48 Single-mode ITU G.652.D fibers AFL SHIPPING MEMO	0.920/ft	14 WKS, D409	
21ea	615883   6258G13 GROUND ROD- 5/8" X 8' CU CLAD STEEL REA 13 MIL SPEC (6258G13) (C615883)	25.000/ea	STK, E301-302	
** Continued on Next Page *		Subtotal		
		S&H Charges		
		Tax		
		Amount Due		



**Fletcher-Reinhardt Company**

Wholesale Distributors of Electric Utility and Industrial Equipment

FLETCHER-REINHARDT CO.  
 3105 CORPORATE EXCHANGE CT  
 BRIDGETON, MO 63044-3722  
 314-506-0700  
 Fax 314-506-0705



**Quotation**

QUOTE DATE	QUOTE NUMBER
06/24/2026	S1368817
FLETCHER-REINHARDT CO. 3105 CORPORATE EXCHANGE CT BRIDGETON, MO 63044-3722 314-506-0700 Fax 314-506-0705	PAGE NO.  7 of 15

QUOTE TO:  
 RANTOUL VILLAGE  
 ACCOUNTS PAYABLE  
 333 S TANNER ST  
 RANTOUL, IL 61866-2919

SHIP TO:  
 RANTOUL, VILLAGE OF  
 WAREHOUSE / GPS COOR  
 621 COOK ST BLDG 729  
 RANTOUL, IL 61866

CUSTOMER NUMBER	CUSTOMER PO NUMBER	JOB NAME / RELEASE NUMBER	SALESPERSON	
4237	Express Line Material		Kris Thoele	
WRITER	SHIP VIA	TERMS	EXPIRE DATE	FREIGHT ALLOWED
Evan Price	F-R FRIDAY-1	Net 30 Days	07/23/2026	Yes
ORDER QTY	DESCRIPTION	UNIT PRICE	COMMENTS	
3ea	URS1005-0A1A-1A1A ARRESTER, POLYMER ULTRASIL RISER POLE VARISTAR (GAPLESS) 10 KV 8.4 KV MCOV WIRE CLAMP UNIVERSAL WILDLIFE PROTECTOR BLACK ISOLATOR INSULATING MOUNTING BASE, NO X-ARM BRACKET	120.000/ea	10 WKS, E501	
9ea	UJ306623M2 3 PHASE ENCLOSURE, SECTIONALIZING, PENTA-HEAD BOLT W/ PADLOCK SECURITY, 15kv, 30"H x 66"W x 23"D *DS*	1965.000/ea	4 WKS, J204	
27ea	^UJP1G Utility Junction Cabinet Pnl 1 Park Stand StyleA, 11.66x18.50, White, Galv Steel SHIPPING MEMO	83.000/ea	4 WKS, J205	
9ea	GS-67-24-24M-MG-60x14 GROUND SLEEVE, 67"W x 24"D x 24"H, 60"W x 14"D OPENING, MUNSELL GREEN NORDIC *DS*	980.000/ea	18 WKS, J206	
27ea	DJ625A4U JUNCTION 15/25KV 600A DEAD-BREAK 4-WAY ALUMINUM WITH U-STRAPS	525.000/ea	14 WKS, J207	
** Continued on Next Page *		Subtotal		
		S&H Charges		
		Tax		
		Amount Due		

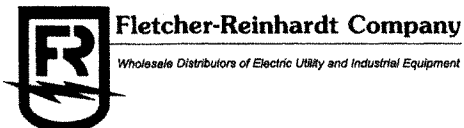

FLETCHER-REINHARDT CO.  
 3105 CORPORATE EXCHANGE CT  
 BRIDGETON, MO 63044-3722  
 314-506-0700  
 Fax 314-506-0705

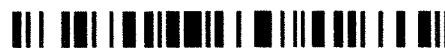

# Quotation

QUOTE DATE	QUOTE NUMBER
06/24/2026	S1368817
FLETCHER-REINHARDT CO. 3105 CORPORATE EXCHANGE CT BRIDGETON, MO 63044-3722 314-506-0700 Fax 314-506-0705	PAGE NO.  8 of 15

QUOTE TO:  
 RANTOUL VILLAGE  
 ACCOUNTS PAYABLE  
 333 S TANNER ST  
 RANTOUL, IL 61866-2919

SHIP TO:  
 RANTOUL, VILLAGE OF  
 WAREHOUSE / GPS COOR  
 621 COOK ST BLDG 729  
 RANTOUL, IL 61866

CUSTOMER NUMBER	CUSTOMER PO NUMBER	JOB NAME / RELEASE NUMBER	SALESPERSON	
4237	Express Line Material		Kris Thoele	
WRITER	SHIP VIA	TERMS	EXPIRE DATE	FREIGHT ALLOWED
Evan Price	F-R FRIDAY-1	Net 30 Days	07/23/2026	Yes
ORDER QTY	DESCRIPTION	UNIT PRICE	COMMENTS	
4ea	^17301903   1730-24 Duralite / LW Unit, Flush Cover T22 Gray, 2x 1/2-6 Hex Auger CpBlit, Fiber Optics SHIPPING MEMO	895.000/ea	2 WKS, K707	
9ea	^FI-3C S04BCX Recon - Underground FCI (4-Hour Fault Reset; Low Battery Indication; Large Clamp; Time/Manual Reset). 6ft fiber cable included SGS SHIPPING MEMO	292.000/ea	8 WKS, K820	
3ea	^FI-3C PH-HEX Fiber Cable (Three-Phase - 6ft). Hex fixing stud included. SGS SHIPPING MEMO	80.000/ea	8 WKS, K838	
** Continued on Next Page *		Subtotal		
		S&H Charges		
		Tax		
		Amount Due		

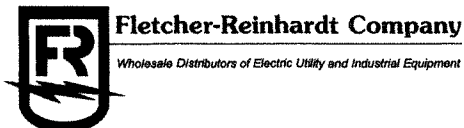

**Fletcher-Reinhardt Company**

Wholesale Distributors of Electric Utility and Industrial Equipment

FLETCHER-REINHARDT CO.  
 3105 CORPORATE EXCHANGE CT  
 BRIDGETON, MO 63044-3722  
 314-506-0700  
 Fax 314-506-0705



# Quotation

QUOTE DATE	QUOTE NUMBER
06/24/2026	S1368817
FLETCHER-REINHARDT CO. 3105 CORPORATE EXCHANGE CT BRIDGETON, MO 63044-3722 314-506-0700 Fax 314-506-0705	PAGE NO.
	9 of 15

QUOTE TO:  
 RANTOUL VILLAGE  
 ACCOUNTS PAYABLE  
 333 S TANNER ST  
 RANTOUL, IL 61866-2919

SHIP TO:  
 RANTOUL, VILLAGE OF  
 WAREHOUSE / GPS COOR  
 621 COOK ST BLDG 729  
 RANTOUL, IL 61866

CUSTOMER NUMBER	CUSTOMER PO NUMBER	JOB NAME / RELEASE NUMBER	SALESPERSON	
4237	Express Line Material		Kris Thoele	
WRITER	SHIP VIA	TERMS	EXPIRE DATE	FREIGHT ALLOWED
Evan Price	F-R FRIDAY-1	Net 30 Days	07/23/2026	Yes
ORDER QTY	DESCRIPTION	UNIT PRICE	COMMENTS	
9ea	^FI-3C T1 Cable trainer for FI-3C remote fiber optic cable, standard, without steel plate. SGS SHIPPING MEMO	28.000/ea	8 WKS, K841	
1ea	^PVCCA06 6" End Cap, PVC, 2-3/4" Length, 6-5/8" ID, 0.1875" thick SHIPPING MEMO	108.000/ea	2 WKS, L208	
3ea	59017N 6" GUARD, RISER, SCH40 PVC MOLD, WITH LAG SCREW SLOTS, 10'L (CPI-46100) (15/CTN) PRIME	155.000/ea	STK, L290	
1ea	E939NRT ADAPTER- 4" PV MOLD TO 6" PVC PIPE TYPE, PRIME	154.000/ea	3 WKS, L292	
3000ft	49013-010 CONDUIT- PVC, 3", SCH40, 10FT LENGTHS, w/ BELLED END (880/LIFT) (49013-010) (3PVC) (UP&S: 63124)	2.500/ft	6 WKS, L298	
** Continued on Next Page *		Subtotal		
		S&H Charges		
		Tax		
		Amount Due		

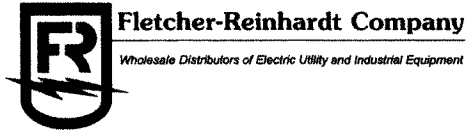

FLETCHER-REINHARDT CO.  
 3105 CORPORATE EXCHANGE CT  
 BRIDGETON, MO 63044-3722  
 314-506-0700  
 Fax 314-506-0705



# Quotation

QUOTE DATE	QUOTE NUMBER
06/24/2026	S1368817
FLETCHER-REINHARDT CO. 3105 CORPORATE EXCHANGE CT BRIDGETON, MO 63044-3722 314-506-0700 Fax 314-506-0705	
PAGE NO.	
10 of 15	

QUOTE TO:  
 RANTOUL VILLAGE  
 ACCOUNTS PAYABLE  
 333 S TANNER ST  
 RANTOUL, IL 61866-2919

SHIP TO:  
 RANTOUL, VILLAGE OF  
 WAREHOUSE / GPS COOR  
 621 COOK ST BLDG 729  
 RANTOUL, IL 61866

CUSTOMER NUMBER	CUSTOMER PO NUMBER	JOB NAME / RELEASE NUMBER	SALESPERSON		
4237	Express Line Material		Kris Thoele		
WRITER		SHIP VIA	TERMS	EXPIRE DATE	FREIGHT ALLOWED
Evan Price		F-R FRIDAY-1	Net 30 Days	07/23/2026	Yes
ORDER QTY	DESCRIPTION		UNIT PRICE	COMMENTS	
6000ft	49017-010 CONDUIT- PVC, 6", NM SCH 40, 10' LENGTHS, ETL-LISTED (TO UL SPEC), W/ONE BELLED END CARLON PRIME (260'/LIFT)		7.000/ft	6 WKS, L300	
40ea	^876897 Conduit Fitting 90 Deg Elbow, 6 in, Threaded, Steel, Galvanized, Silver		1060.000/ea	4 WKS, L311	
900ft	SHIPPING MEMO ^2051709210 6" /Schedule-80 /Listed /Smooth-Wall /UV Black (2% Ash/ 4% LD) /UV Red /No Lube /Empty /Ink Jet /Listed Print /Straight Length /Stick Pipe /40 No. of Sticks: 23 HDP600WSCHE80SWUVSUVRNEMPTDVSL TIX00040 DURA-LINE SHIPPING MEMO		9.400/ft	13 WKS, L340	
** Continued on Next Page *			Subtotal		
			S&H Charges		
			Tax		
			Amount Due		



**Fletcher-Reinhardt Company**

Wholesale Distributors of Electric Utility and Industrial Equipment

FLETCHER-REINHARDT CO.  
 3105 CORPORATE EXCHANGE CT  
 BRIDGETON, MO 63044-3722  
 314-506-0700  
 Fax 314-506-0705



**Quotation**

QUOTE DATE	QUOTE NUMBER
06/24/2026	S1368817
FLETCHER-REINHARDT CO. 3105 CORPORATE EXCHANGE CT BRIDGETON, MO 63044-3722 314-506-0700 Fax 314-506-0705	PAGE NO.
	11 of 15

QUOTE TO:  
 RANTOUL VILLAGE  
 ACCOUNTS PAYABLE  
 333 S TANNER ST  
 RANTOUL, IL 61866-2919

SHIP TO:  
 RANTOUL, VILLAGE OF  
 WAREHOUSE / GPS COOR  
 621 COOK ST BLDG 729  
 RANTOUL, IL 61866

CUSTOMER NUMBER	CUSTOMER PO NUMBER	JOB NAME / RELEASE NUMBER	SALESPERSON	
4237	Express Line Material		Kris Thoele	
WRITER	SHIP VIA	TERMS	EXPIRE DATE	FREIGHT ALLOWED
Evan Price	F-R FRIDAY-1	Net 30 Days	07/23/2026	Yes
ORDER QTY	DESCRIPTION	UNIT PRICE	COMMENTS	
1000ft	^10003803 3" /Schedule-80 /Listed /Smooth-Wall /UV Black (2% Ash/ 4% LD) /UV Red /No Lube /1,250# Poly Tape /Ink Jet /Listed Print /Steel /SR 96x45 Wide /1,000 No. of Reels: 1 HDP300WSCHE80SWUVSUVRNPP12DVSRS 96X01000 DURA-LINE SHIPPING MEMO	4.150/ft	7 WKS, L341	
40ea	^BRID 332 6" PLASTIC BUSHING SHIPPING MEMO	50.850/ea	4 WKS, L359	
1ea	R3CSA-48 BRACKET- AL EQUIPMENT MOUNT, 3 PHASE H.D. 48" CURVED TUBE TYPE, EA POSITION ADJ. 0° TO 20° FORWARD INCLINATION FOR SWITCHES / TERMINATIONS, **[(2) 5/8" THRU BOLTS & (2) LAG SCREW MT HARDWARE NOT INCLUDED]** (51831) ALUMA FORM *DS*	665.000/ea	STK, L257	
** Continued on Next Page *		Subtotal		
		S&H Charges		
		Tax		
		Amount Due		

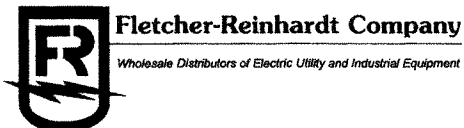

FLETCHER-REINHARDT CO.  
 3105 CORPORATE EXCHANGE CT  
 BRIDGETON, MO 63044-3722  
 314-506-0700  
 Fax 314-506-0705



# Quotation

QUOTE DATE	QUOTE NUMBER
06/24/2026	S1368817
FLETCHER-REINHARDT CO. 3105 CORPORATE EXCHANGE CT BRIDGETON, MO 63044-3722 314-506-0700 Fax 314-506-0705	PAGE NO.  12 of 15

QUOTE TO:  
 RANTOUL VILLAGE  
 ACCOUNTS PAYABLE  
 333 S TANNER ST  
 RANTOUL, IL 61866-2919

SHIP TO:  
 RANTOUL, VILLAGE OF  
 WAREHOUSE / GPS COOR  
 621 COOK ST BLDG 729  
 RANTOUL, IL 61866

CUSTOMER NUMBER	CUSTOMER PO NUMBER	JOB NAME / RELEASE NUMBER	SALESPERSON	
4237	Express Line Material		Kris Thoele	
WRITER	SHIP VIA	TERMS	EXPIRE DATE	FREIGHT ALLOWED
Evan Price	F-R FRIDAY-1	Net 30 Days	07/23/2026	Yes
ORDER QTY	DESCRIPTION	UNIT PRICE	COMMENTS	
	----- NO QUOTE 59117 (6" BACKING PLATE). DISCONTINUED BY MFG. NO ALT -----			
42ea	E942R ADAPTER, FEMALE, 6" PVC SCH40 TO 6" GALV CONDUIT (PRIME FA600) (6/CTN)	16.000/ea	6 WKS, L366	
2ea	E942L ADAPTER- 3" PVC FEMALE (INSIDE THREADS), PVC TO PVC OR METALLIC SYSTEMS, SCH40 OR SCH 80 FEMALE SLIP ON TYPE, COLOR: GRAY TNB/CARLON	16.000/ea	STK, L368	
4ea	E940R COUPLING- PVC 6" SCH 40, STD TYPE WITH CENTER STOP, 4.625"LENGTH CARLON (5/CTN)	35.000/ea	STK, L369	
3ea	LRTP615 PLUG, LOADBREAK, REDUCING TAP, BUSHING, 15KV, 600A, LB, T-OPII w/THREADED FLOATING NUT (NOT COMPATIBLE w/STANDARD DEADBREAK ELBOWS) *DS* * Sub for: P615LRTP PLUG- LOADBREAK	330.000/ea	STK, R405	
** Continued on Next Page *		Subtotal		
		S&H Charges		
		Tax		
		Amount Due		

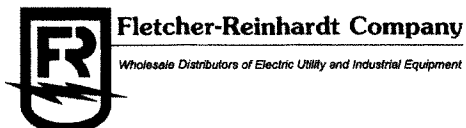

**Fletcher-Reinhardt Company**

Wholesale Distributors of Electric Utility and Industrial Equipment

FLETCHER-REINHARDT CO.  
 3105 CORPORATE EXCHANGE CT  
 BRIDGETON, MO 63044-3722  
 314-506-0700  
 Fax 314-506-0705



# Quotation

QUOTE DATE	QUOTE NUMBER
06/24/2026	S1368817
FLETCHER-REINHARDT CO. 3105 CORPORATE EXCHANGE CT BRIDGETON, MO 63044-3722 314-506-0700 Fax 314-506-0705	PAGE NO.  13 of 15

QUOTE TO:  
 RANTOUL VILLAGE  
 ACCOUNTS PAYABLE  
 333 S TANNER ST  
 RANTOUL, IL 61866-2919

SHIP TO:  
 RANTOUL, VILLAGE OF  
 WAREHOUSE / GPS COOR  
 621 COOK ST BLDG 729  
 RANTOUL, IL 61866

CUSTOMER NUMBER	CUSTOMER PO NUMBER	JOB NAME / RELEASE NUMBER	SALESPERSON	
4237	Express Line Material		Kris Thoele	
WRITER	SHIP VIA	TERMS	EXPIRE DATE	FREIGHT ALLOWED
Evan Price	F-R FRIDAY-1	Net 30 Days	07/23/2026	Yes
ORDER QTY	DESCRIPTION	UNIT PRICE	COMMENTS	
3ea	M3D-66BP SWITCH, DISCONNECT, DISTRIBUTION CLASS, 15kV, 110kV BIL, 600A **POLYMER**, HOOKSTICK OP, 40kA (MOMENTARY), W/2 NEMA (#2-500MCM) TINNED PG CLAMPS (ATC1343) INCLUDED, CROSSARM MOUNT BASE, HPS *DS* **NOTES**	480.000/ea	STK, R114	
3ea	60-1312   U162-SWB-PGE GRIP- SUSPENSION, CABLE SUPPORT, LIGHT DUTY, UNCOATED GAL. STEEL WIRE, CABLE RANGE (OD): 1-5/8"-2-1/2" WORKING LOAD 2250 LBS, 5000 LB RBS, 16"L MESH, EYE LENGTH: 16", (60-1312) LEWIS MFG *DS*	32.000/ea	STK, S149	
3ea	J3318 HOOK, DRIVE, 5/16" X 3-1/2" DRIVE POINT, HOT DIP GALVANIZED STEEL MPS, STD PKG ONLY (400/CTN) *DS*	2.750/ea	STK, S148	
** Continued on Next Page *		Subtotal		
		S&H Charges		
		Tax		
		Amount Due		

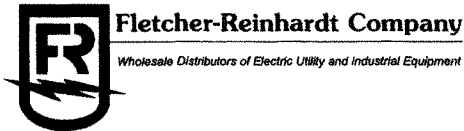

**Fletcher-Reinhardt Company**

Wholesale Distributors of Electric Utility and Industrial Equipment

FLETCHER-REINHARDT CO.  
 3105 CORPORATE EXCHANGE CT  
 BRIDGETON, MO 63044-3722  
 314-506-0700  
 Fax 314-506-0705



# Quotation

QUOTE DATE	QUOTE NUMBER
06/24/2026	S1368817
FLETCHER-REINHARDT CO. 3105 CORPORATE EXCHANGE CT BRIDGETON, MO 63044-3722 314-506-0700 Fax 314-506-0705	PAGE NO.
	14 of 15

QUOTE TO:  
 RANTOUL VILLAGE  
 ACCOUNTS PAYABLE  
 333 S TANNER ST  
 RANTOUL, IL 61866-2919

SHIP TO:  
 RANTOUL, VILLAGE OF  
 WAREHOUSE / GPS COOR  
 621 COOK ST BLDG 729  
 RANTOUL, IL 61866

CUSTOMER NUMBER	CUSTOMER PO NUMBER	JOB NAME / RELEASE NUMBER	SALESPERSON	
4237	Express Line Material		Kris Thoele	
WRITER	SHIP VIA	TERMS	EXPIRE DATE	FREIGHT ALLOWED
Evan Price	F-R FRIDAY-1	Net 30 Days	07/23/2026	Yes
ORDER QTY	DESCRIPTION	UNIT PRICE	COMMENTS	
57ea	^TP615FF25TC 600A, 15 kV, AC 1 min: 34 kV, DC 15 min: 53 kV, BIL: 95 kV, Min corona: 11 kV, Cable insul: 1.26-1.64 inch, Strand: 750 kcmil, Solid: 900 kcmil SHIPPING MEMO	640.000/ea	12 WKS, U200	
60ea	DPC625 CAP - BUSHING, INSULATING, 15/25KV, 600A, W/STATIC DRAIN WIRE Standard Protective Cap with Drain Wire with Permanent Stud (BULK BOXED)(30/CTN)	117.000/ea	10 WKS, U400	
3ea	215ELA10 ARRESTER - ELBOW, 10KV DUTY CYCLE, 8.4KV MCOV, MOV, POLYMER, 15KV/200A BUSHING (OLD PART# 611509-0036) HPS *DS*	266.180/ea	STK, U501	
** Continued on Next Page *		Subtotal		
		S&H Charges		
		Tax		
		Amount Due		

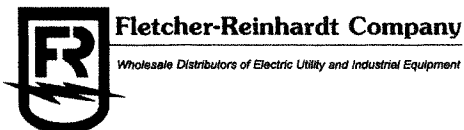

FLETCHER-REINHARDT CO.  
3105 CORPORATE EXCHANGE CT  
BRIDGETON, MO 63044-3722  
314-506-0700  
Fax 314-506-0705



# Quotation

QUOTE DATE	QUOTE NUMBER
06/24/2026	S1368817
FLETCHER-REINHARDT CO. 3105 CORPORATE EXCHANGE CT BRIDGETON, MO 63044-3722 314-506-0700 Fax 314-506-0705	PAGE NO.  15 of 15

QUOTE TO:  
RANTOUL VILLAGE  
ACCOUNTS PAYABLE  
333 S TANNER ST  
RANTOUL, IL 61866-2919

SHIP TO:  
RANTOUL, VILLAGE OF  
WAREHOUSE / GPS COOR  
621 COOK ST BLDG 729  
RANTOUL, IL 61866

CUSTOMER NUMBER	CUSTOMER PO NUMBER	JOB NAME / RELEASE NUMBER	SALESPERSON	
4237	Express Line Material		Kris Thoele	
WRITER	SHIP VIA	TERMS	EXPIRE DATE	FREIGHT ALLOWED
Evan Price	F-R FRIDAY-1	Net 30 Days	07/23/2026	Yes
ORDER QTY	DESCRIPTION	UNIT PRICE	COMMENTS	
3ea	7655-S-4 KIT- TERMINATION, OUTDOOR QT-III, 4-SKIRT, 150kV BIL, COND INS OD RANGE: 1.05"-1.80" 5kV (700-1500 MCM) 8.7 kV (600-1250 MCM) 15 kV (500-1000 MCM) 25/28 kV (250-800 MCM), **FOR JACKETED CONCENTRIC NEUTRAL (JCN) CABLE** 3M (1 TERM/KIT) *DS*	255.000/ea	STK, U503	

TERMS: NET 30 DAYS with payment via Check or ACH.  
F.O.B. Point of Shipment, Freight Allowed unless otherwise stated.  
This Quotation, including prices & lead-time, is subject to change in the event of delays and adverse impacts that may be caused by forces beyond Fletcher-Reinhardt Company's (FR) control. FR's Standard Terms and Conditions (T&C) of Sale apply to any purchase from FR. Link to FR T&C: <https://www.fr-electric.com/index.jsp?path=terms>  
We appreciate your business.

Subtotal	236670.29
S&H Charges	0.00
Tax	0.00
<b>Amount Due</b>	<b>236670.29</b>



1100 Old State Road  
Mattoon, IL 61938

BHMG EXPRESS LINE BOM

www.anixterpowersolutions.com

Phone: 217.235.0546  
Fax: 217.235.0024

Quotation: U00806625.00

To: **RANTOUL LIGHT & POWER DEPT**  
**729 COOK STREET**  
**RANTOUL, IL 61866**

Issued Date: **May 18, 2026**  
Expiration Date: **Jun 13, 2026**

Attn:  
Phone:  
Fax:

Sales Contact: **Ava Bennett**  
**(P)**  
**(F)**  
**ava.bennett@wescodist.com**

Item	CustLine	Product and Description	Quantity	Price	Unit	Extended
1		<b>QL2-A-350-750</b> BOLT SHEAR LUGS 2 HOLE 750  DEL: 2-4 WEEKS	3	202.59	EA	607.77
2		<b>ST4</b> ZINC COND HUB STRT 1-1/4 INSUL THROAT WEATHERTITE <b>STD PKG: 10</b>  DEL: 6-8 WEEKS	12	29.74	EA	356.86
3		<b>GRC58</b> CLAMP GRC 5/8" FOR 5/8" GRD ROD <b>STD PKG: 100</b>  DEL: STOCK	18	2.75	EA	49.50
4		<b>GTCS41</b> CONN TRAN GRD BRZ 8 SOL-250 SOL 2POS <b>STD PKG: 50</b>  DEL: 1-2 WEEKS	18	32.61	EA	587.05
5		<b>GC1112C3</b> GROUND CLAMP  DEL: 18-20 WEEKS	4	72.82		291.27
6		<b>YC28C28</b> CONNECTOR COMPRESSION CW 3/0-4/0 MAIN & TAP <b>STD PKG: 50</b>  DEL: STOCK	84	5.17	EA	434.32
7		<b>494-82</b> CONNECTOR COMPRESSN TAP <b>STD PKG: 25</b>  DEL: 2-4 WEEKS	4	9.55	EA	38.20



1100 Old State Road  
Mattoon, IL 61938

BHMG EXPRESS LINE BOM

Phone: 217.235.0546  
Fax: 217.235.0024

www.anixterpowersolutions.com

Quotation: U00806625.00

Item	CustLine	Product and Description	Quantity	Price	Unit	Extended
8		<b>YH2929</b> CONNECTOR OVERHEAD T TD COMPRESSION  DEL: 1-2 WEEKS	12	14.10	EA	169.23
9		<b>490-82</b> H-TAPS <b>STD PKG: 50</b> DEL: 7-9 WEEKS	3	7.34	EA	22.02
10		<b>J8814</b> BOLT MACH 5/8"X14" <b>STD PKG: 25</b> DEL: STOCK	2	2.38	EA	4.75
11		<b>3512</b> NUT MF LOCK CURVED 5/8" <b>STD PKG: 1000</b> DEL: 1-2 WEEKS	2	0.35	EA	0.70
12		<b>J3540</b> WASHER SPRING FOR 5/8" BOLT <b>STD PKG: 50</b> DEL: STOCK	2	4.89	EA	9.77
13		<b>6812</b> WASHER SQ 2" 1/8" GA 11/16" HOLE <b>STD PKG: 300</b> DEL: 1-2 WEEKS	2	0.68	EA	1.36
14		<b>681012</b> WASHER CURVED 2.25" SQ 5/8"  DEL: 4-6 WEEKS	2	1.94	EA	3.89
15		<b>T2050428</b> NAIL COPPERCLAD SIZE 3D  DEL: 1-2 WEEKS	20	0.74		14.77
16		<b>508754</b> SCREW LAG 1/2" X 4" FETTER DRIVE <b>STD PKG: 150</b> DEL: 1-2 WEEKS	2	2.03	EA	4.07



1100 Old State Road  
Mattoon, IL 61938

BHMG EXPRESS LINE BOM

Phone: 217.235.0546  
Fax: 217.235.0024

www.anixterpowersolutions.com

Quotation: U00806625.00

Item	CustLine	Product and Description	Quantity	Price	Unit	Extended
17		<b>DF1L3</b> LAG SCREW GIMLET 1/4X3" STD PKG: 1000 DEL: 1-2 WEEKS	50	2.02	EA	101.14
18		<b>EMHOTB1</b> CLIP TB1 3" ANCHOR DEL: 1-2 WEEKS	4	9.93		39.73
19		<b>LW14SS</b> LOCK WASHER 1/4" SS DEL: NO QUOTE	24		EA	No Quote
20		<b>N14SS</b> DEL: NO QUOTE	12			No Quote
21		<b>50X150HSSBUSA</b> Bolt, 1/2"x1-1/2" Stainless Steel, 1 nut DEL: 1-2 WEEKS	12	3.69		44.32
22		<b>50X106BWSS</b> WASHER BELLEVILLE 1/2" SS DEL: 1-2 WEEKS	12	1.98	EA	23.73
23		<b>F6SOLSDB-BK</b> 6 SOLID SOFT DRAWN BARE CU, 1 X 30'R DEL: STOCK	30	1.14	FT	34.09
24		<b>MERLIN30R</b> 336.4ACSR-18/1-BULK, 1 X 30R DEL: STOCK	30	2.07	FT	62.05
25		<b>F2-7STRSDB-BK</b> 2 7STR SOFT DRAWN BARE CU 1 X 90R DEL: STOCK	90	2.20	FT	197.90
26		<b>F4/0-7STRSDBC-BK</b> 4/0 7STR SOFT DRAWN BARE CU DEL: STOCK	60	6.96	FT	417.48



1100 Old State Road  
Mattoon, IL 61938

BHMG EXPRESS LINE BOM

Phone: 217.235.0546  
Fax: 217.235.0024

www.anixterpowersolutions.com

Quotation: U00806625.00

Item	CustLine	Product and Description	Quantity	Price	Unit	Extended
27		<b>F14SOLSDB-BK</b> 14 SOL SOFT DRAWN BARE CU 1 X 285'R  DEL: 1 WEEK	285	0.17	FT	48.58
28		<b>UG FIBER</b>  DEL: NO QUOTE	4200			No Quote
29		<b>615883</b> ROD GROUND 5/8 X 8 FT CU 13MIL REA NON-TH YEL <b>STD PKG: 5</b> DEL: STOCK	17	20.20	EA	343.39
30		<b>615840</b> GROUND ROD CU 5/8"D 4'L  DEL: 6-8 WEEKS	4	8.57	EA	34.27
31		<b>URS-1005-0A1A-1A1A</b>  DEL: 9-10 WEEKS	3	47.60		142.81
32		<b>GS-75-73-36-MG-67X62</b> FIBERGLASS ENCLOSURE GROUND SLEEVE <b>STD PKG: 8</b> DEL: STOCK	1	1,668.43	EA	1,668.43
33		<b>UJ306623M2</b>  DEL: NO QUOTE	9			No Quote
34		<b>UJP1G</b>  DEL: NO QUOTE	27			No Quote
35		<b>GS-67-24-24M-MG-60x14</b> GROUND SLEEVE JUNCTION BOX  DEL: 18-20 WEEKS	9	778.82		7,009.36
36		<b>DJ625A4</b> JUNCTION  DEL: 4-6 WEEKS	27	483.60	EA	13,057.11



1100 Old State Road  
Mattoon, IL 61938

BHMG EXPRESS LINE BOM

www.anixterpowersolutions.com

Phone: 217.235.0546  
Fax: 217.235.0024

Quotation: U00806625.00

Item	CustLine	Product and Description	Quantity	Price	Unit	Extended
37		STONE  DEL: NO QUOTE	1			No Quote
38		CONCRETE  DEL: NO QUOTE	1			No Quote
39		APC173024PCT22  DEL: NO QUOTE	4			No Quote
40		FI-3C S04BCX  DEL: NO QUOTE	9			No Quote
41		FI-3C PH-HEX  DEL: NO QUOTE	3			No Quote
42		FI-3C T1  DEL: NO QUOTE	9			No Quote
43		PVCCA06  DEL: NO QUOTE	1			No Quote
44		59017N RISER PV-MOLD 6"X10"L HVY D FLANGED BELLED STD PKG: 30 DEL: 1-2 WEEKS	3	221.59	EA	664.77
45		E939NRT 4" PV MOLX 6" PIPE ADAPTER DEL: 1-2 WEEKS	1	113.64		113.64
46		49013-010 CONDUIT PVC 3"X10'L SCH40 STD PKG: 880 DEL: STOCK	3000	1.73	FT	5,193.51



1100 Old State Road  
Mattoon, IL 61938

**BHMG EXPRESS LINE BOM**

www.anixterpowersolutions.com

Phone: 217.235.0546  
Fax: 217.235.0024

**Quotation: U00806625.00**

Item	CustLine	Product and Description	Quantity	Price	Unit	Extended
47		<b>49017-010</b> CONDUIT PVC 6"X10'L SCH40 STD PKG: 260 DEL: STOCK	6000	6.65	FT	39,886.36
48		<b>876897</b> 6X90X60 GRC ELBOW DEL: 4-6 WEEKS	40	1,136.76		45,470.45
49		<b>U222C9N1A3KA450</b> DEL: CARLON NO LONGER OFFERS HDPE	900			No Quote
50		<b>U15C5N1A3KB1000</b> DEL: CARLON NO LONGER OFFERS HDPE	700			No Quote
51		.	38			No Quote
52		<b>R3CSA-48</b> MOUNT EQUIPMENT FOR 6 PCS HD STD PKG: 2 DEL: 6-8 WEEKS	1	490.78	EA	490.78
53		<b>59117</b> 6" PVMOLD BACKPLATE FLAT TYPE DEL: 1-2 WEEKS	3	63.07		189.20
54		<b>FA60</b> ADAPTER PVC DB 5" DEL: 1-2 WEEKS	40	4.09	EA	163.45
55		<b>E942L</b> ADAPTER PVC FEM 3" DEL: 1-2 WEEKS	2	4.09	EA	8.17
56		<b>E940R</b> COUPLING PVC 6" SCH40 SKT TYPE DEL: 1-2 WEEKS	4	3.14	EA	12.54



1100 Old State Road  
Mattoon, IL 61938

BHMG EXPRESS LINE BOM

Phone: 217.235.0546  
Fax: 217.235.0024

www.anixterpowersolutions.com

Quotation: **U00806625.00**

Item	CustLine	Product and Description	Quantity	Price	Unit	Extended
57		<b>PSE-10-44400</b> 15KV 95KV BIL PME-10 PADMOUNT SWITCHGEAR  DEL: 24-26 WEEKS	1	26,704.26	EA	26,704.26
58		<b>DBA615</b> BUSH ADAPT WITH LRTP & EXT 2637834B04M  DEL: STOCK	3	442.22	EA	1,326.66
59		<b>MBH66B</b> SWITCH M3H 15KV 110BIL 600A  DEL: 10-12 WEEKS	3	354.01		1,062.03
60		<b>U162-SWB-PGE</b> 750 MCM CABLE GRIP  DEL: 1-2 WEEKS	3	26.16		78.48
61		<b>PSC2050605</b> HOOK DRIVE 5/16IN DIA X 3-1/2IN LENGTH  DEL: 1-2 WEEKS	3	0.82	EA	2.45
62		<b>TP615FF25TC</b> DBB TOP 600A 15KV LB CAP  DEL: 10-12 WEEKS	57	580.32		33,078.14
63		<b>DPC625</b> CAP PROTECTIVE DRAIN WIRE 600A <b>STD PKG: 15</b>  DEL: STOCK	54	92.94	EA	5,018.93
64		<b>650ETP</b> PLUG ELBOW TAP 200 AMP  DEL: 1-2 WEEKS	3	204.33	EA	612.99
65		<b>7655-S-4</b> TERMINATION KIT COLD SHRINK 150KV  DEL: 5-7 WEEKS	3	251.21	EA	753.63

**SECTION TOTAL:** \$186,650.38

**QUOTE TOTAL:** \$186,650.38

**Special Notes**

- 1) All items are In Stock unless otherwise noted.
- 2) All item pricing on this quote is valid for thirty days unless otherwise specified.
- 3) All applicable taxes apply.



1100 Old State Road  
Mattoon, IL 61938

**BHMG EXPRESS LINE BOM**

[www.anixterpowersolutions.com](http://www.anixterpowersolutions.com)

Phone: 217.235.0546  
Fax: 217.235.0024

**Quotation: U00806625.00**

---

BY ACCEPTING THIS QUOTE, YOU AGREE THE WESCO TERMS CONDITIONS PUBLISHED AT [WWW.WESCO.COM/TERMSOFSALE](http://WWW.WESCO.COM/TERMSOFSALE) ARE EXPRESSLY INCORPORATED INTO AND GOVERN THIS TRANSACTION. Storage transport fees may apply if delivery isn't accepted w/in 90 days of availability. Price subject to change based on duties, freight, tariffs, or supplier increases.

---

**Anixter Power Solutions offers the industry's most extensive and dynamic portfolio of products, services and solutions for the Public Power, Investor-owned Utilities, Construction and Industrial markets.**

**BOARD OF TRUSTEES  
VILLAGE OF RANTOUL**

**AGENDA ITEM**

<p>ITEM: Service Agreement for the Construction Engineering and Support for the Electric Department's Prospect Substation and Feeder Exits Project with BHMG Engineers, Inc. in the amount not-to-exceed \$400,000.00</p>	<p>DEPARTMENT: Public Works</p>
<p>DATE: July 7, 2026</p>	<p>AMOUNT: Not-to-Exceed \$400,000.00</p>
<p>ATTACHMENTS:</p> <p>1. BHMG Engineers, Inc - Construction Engineering Agreement</p>	<p>ADMINISTRATIVE NOTES:</p>
<p><b>SUMMARY HIGHLIGHTS:</b></p> <p>This Agenda item provides for a Construction Engineering and Support Agreement with BHMG Engineers, Inc. in the amount not-to-exceed \$400,000.00 for the Prospect Substation and Feeder Exits Project.</p> <p>The attached document outlines the BHMG Engineers scope of work, which includes field support, contractor coordination, contractor pay requests, change order review, and progress reports. This is a not-to-exceed amount comparable to their estimate.</p> <p>Prospect Substation Estimate of Cost:</p> <ul style="list-style-type: none"> <li>▪ \$ 2,347,422.00 - Switchgear (delivery December 1, 2026)</li> <li>▪ \$ 5,896,930.50 - Transformers (delivery August 24, 2026)</li> <li>▪ \$ 1,500,000.00 - Line Feeders</li> <li>▪ \$ 1,260,400.00 - Engineering</li> <li>▪ \$ 404,403.00 - Construction Engineering</li> <li>▪ <u>\$ 5,604,219.50 - Construction</u></li> <li>▪ \$17,013,375.00 Total</li> </ul> <p>These Construction Engineering fees will be funded out of the Electric Department Bond Reserves.</p>	
<p><b>RECOMMENDED ACTION:</b> Authorize the approval for a construction engineering</p>	

agreement with BHMG engineers in the amount not to exceed of \$400,000.00 to construct the new Prospect Substation and Feeder Exits project.

DEPARTMENT HEAD APPROVAL  
Chad Isley

VILLAGE ADMINISTRATOR  
Scott Eisenhauer



Scott Eisenhauer

June 29, 2026

Village Administrator

E: [seisenhauer@village.rantoul.il.us](mailto:seisenhauer@village.rantoul.il.us)

Ref: Cost Proposal – Prospect Substation & Feeder Exits Construction Support & Administration

Dear Mr. Scott Eisenhauer,

Thank you again for coming to BHMG for a proposal on the Construction Support & Administration on the Prospect Substation & Feeder Exits project. The scope is outlined below:

- Sites Visits & Field Support
- In-office design support for contractor RFIs or proposed changes
- Material coordination
- Contractor coordination & technical support
- Construction Status Calls
- Contractor invoice support (Pay request approval)
- Contractor change order review and coordination
- Outage Sequence Planning Support

See 'Table 1' below for proposed project costs.

Table 1: Consultant Design Cost Proposal

Description	Cost
BHMG Engineering Services	\$ 400,000.00
<b>Time &amp; Expense <u>Estimate</u></b>	<b>\$ 400,000.00</b>

BHMG appreciates this opportunity to provide Rantoul with these services. Should any questions arise, please contact me at your convenience.

Sincerely,

  
**Chris Couch**  
 Project Manager

**BOARD OF TRUSTEES  
VILLAGE OF RANTOUL**

**AGENDA ITEM**

<p>ITEM: Ordinance Authorizing a Binding Referendum on the November 3, 2026 Election Ballot asking, "Shall the Village of Rantoul abandon the method of electing Trustees from districts so that Trustees shall be hereafter elected on a Village-wide basis?"</p>	<p>DEPARTMENT: Administration</p>
<p>DATE: July 7, 2026</p>	<p>AMOUNT:</p>
<p>ATTACHMENTS:</p> <ol style="list-style-type: none"> <li>1. Ordinance - Binding Referendum - Election at Large</li> </ol>	<p>ADMINISTRATIVE NOTES:</p>
<p>SUMMARY HIGHLIGHTS: At the request of Trustees, the Board is being asked to approve an Ordinance seeking to put a binding referendum on the ballot for the general election on November 3rd, 2026 for the voters to decide whether to abandon the election of Trustees by district, and thereafter elect Trustees on a village-wide basis. The Board would ONLY be voting to approve the placement of the referendum on the ballot, NOT the actual decision on whether to abandon the election of Trustees by district.</p>	
<p>RECOMMENDED ACTION:</p>	
<p>DEPARTMENT HEAD APPROVAL Scott Eisenhauer</p>	<p>VILLAGE ADMINISTRATOR Scott Eisenhauer</p>

**ORDINANCE 2834**

**AN ORDINANCE PROVIDING FOR AND REQUIRING THE SUBMISSION OF A BINDING REFERENDUM TO THE VOTERS OF THE VILLAGE OF RANTOUL, CHAMPAIGN COUNTY, ILLINOIS, AT THE GENERAL ELECTION TO BE HELD ON NOVEMBER 3, 2026 TO ABANDON ELECTION OF TRUSTEES BY DISTRICT AND THEREAFTER ELECT TRUSTEES ON A VILLAGE WIDE BASIS**

**WHEREAS**, the Village of Rantoul, Champaign County, Illinois (the “**Municipality**”), is a Home Rule unit pursuant to the provisions of Section 6, Article VII of the 1970 Constitution of the State of Illinois; and,

**WHEREAS**, at the November 6, 2018 general election, the electors of the Village of Rantoul approved a proposition to elect Village Trustees by district; and,

**WHEREAS**, the first Trustees elected by district were sworn in on May 4, 2021, and the Village began operating under the “by district” provision as of that date; and,

**WHEREAS**, the Village has operated for more than four years under the “by district” provision; and,

**WHEREAS**, Article VII, Section 6(f) of the 1970 Constitution of the State of Illinois provides: “A Home Rule municipality shall have the power to provide for its officers, their manner of selection, and terms of office only as approved by referendum or as otherwise authorized by law.”; and,

**WHEREAS**, Sections 3.1-25-80 and 3.1-25-85 of the Illinois Municipal Code (65 ILCS 5/3.1-25-80, 65 ILCS 5/3.1-25-85) do not preempt Home Rule authority granted under Section 6, Article VII of the 1970 Constitution of the State of Illinois; and,

**WHEREAS**, the President and Board of Trustees (the “Corporate Authorities”) have been asked to adopt an Ordinance seeking to put a binding referendum on the ballot for the general election to be held on November 3, 2026 for the voters to decide whether to abandon election of Trustees by district, and thereafter elect Trustees on a Village-wide basis.

**NOW, THEREFORE, BE IT AND IT IS HEREBY ORDAINED BY THE PRESIDENT AND BOARD OF TRUSTEES OF THE VILLAGE OF RANTOUL, CHAMPAIGN COUNTY, ILLINOIS**, as follows:

**Section 1. Election of Trustees.** That the following binding referendum be submitted to the voters of the Village of Rantoul: “Shall the Village of Rantoul abandon the method of electing trustees from districts so that trustees shall be hereafter elected on a Village-wide basis.”

**Section 2. Election.** That the binding referendum hereinabove referred to be submitted to the voters of the Municipality in accordance with the general election law at the general election to be held on Tuesday, the third day of November, 2026, between the hours provided by law for voting on such day (the “**Election**”).

**Section 3. Election Precincts.** That the Election shall be held in the voting precincts and at the polling places established by the County Board (the “**County Board**”) of the County of Champaign, Illinois (the “**County**”), for voters of the Municipality at the Election.

**Section 4. Notice.** That the County Clerk of the County (the “**County Clerk**”) shall give notices of the Election in accordance with the general election law by publishing notice thereof at least once in one or more local, community newspapers published in or having general circulation in the Municipality, the date or dates of such publications of such notices to be not more than 30 nor less than 10 days prior to the date set for the Election, and otherwise in compliance with the applicable election law.

**Section 5. Newspapers.** That the local, community newspapers published in or having general circulation in the Municipality, and the newspaper published in or having general circulation in the County, related to the Election shall be as required by the Election Code of the State of Illinois, as amended (the “**Election Code**”).

**Section 6. Form of Notice.** That the notices of the Election shall include substantially the following (provided that this shall be deemed modified to conform with applicable law):

**NOTICE IS HEREBY GIVEN** that at the general election to be held on Tuesday, the third day of November, 2026, the following binding referendum (modified as may be necessary to comply with applicable law) will be submitted to the voters of the Village of Rantoul, Champaign County, Illinois (The following may be modified to comply with applicable law.):

Shall the Village of Rantoul abandon the method of electing trustees from districts so that trustees shall be hereafter elected on a village wide basis?

The polls at such election will be open at 6:00 o’clock A.M. and continued open until 7:00 o’clock P.M. of that day.

Dated this day of \_\_\_\_\_, 2026.

(facsimile Signature) \_\_\_\_\_  
County Clerk,  
County of Champaign, Illinois

**Section 7. Election.** That the ballot to be used at the Election shall be in substantially the following form with such alterations, changes, insertions, and deletions as required by applicable law, including Article 24A of the Election Code if an electronic, mechanical, or electric voting system (an “**Electronic Voting System**”) is used at the Election:

(Face of Ballot)

**OFFICIAL BALLOT**

**BINDING REFERENDUM TO ABANDON ELECTION OF TRUSTEES BY DISTRICT  
AND HEREAFTER ELECT TRUSTEES ON A VILLAGE-WIDE BASIS IN THE  
VILLAGE OF RANTOUL**

(INSTRUCTIONS TO VOTERS: Punch opposite the word “YES” or “NO” to indicate your choice.)

Shall the Village of Rantoul abandon the method of electing Trustees from districts so that Trustees shall be hereafter elected on a Village-wide basis?

YES

:\_\_\_\_\_:

NO

(Back of Paper Ballot)

**OFFICIAL BALLOT**

Official ballot for voting on the binding referendum to abandon election of trustees by district, and hereafter elect Trustees on a Village-wide basis in the Village of Rantoul, Champaign County, Illinois, at the general election held on November 3, 2026.

Precinct Number: \_\_\_\_\_

Polling Place: \_\_\_\_\_

\_\_\_\_\_

\_\_\_\_\_

(Facsimile Signature)

County Clerk, The County of  
Champaign, Illinois

**Section 8. Electronic Voting.** That, if an Electronic Voting System is used in the County, the County Clerk shall publish, not less than five (5) days prior to the Election, a true and legible copy of the specimen ballot label containing the question to be voted upon at the Election in two or more newspapers published in or having general circulation in the County.

**Section 9. Judges.** That the Election shall be conducted by the election judges appointed by the County Board to act in the precincts at which such proposition will be submitted to the voters of the Municipality.

**Section 10. Certify to County Clerk.** That immediately after the adoption hereof, the Village Clerk shall certify a copy hereof to the County Clerk in order that the binding referendum set forth herein may be submitted to the voters of the Municipality at the Election.

**Section 11. Canvass.** That the Election shall be held and conducted and the returns thereof duly canvassed, all in the manner and time as provided by the general election law.

**Section 12. Conflict.** That all Ordinances and parts of Ordinances in conflict herewith be and the same are hereby repealed, that this Ordinance be in full force and effect forthwith upon its adoption, and that this Ordinance shall be deemed to be subject to modification in application to comply with the general election law.

This Ordinance is hereby passed, the “ayes” and “nays” being called, by the concurrence of a majority of the members of the Corporate Authorities then holding office at a meeting held on the date set forth below.

Upon motion by \_\_\_\_\_, seconded by \_\_\_\_\_, adopted this 14th day of July, 2026 upon a roll call vote as follows:

“Ayes” \_\_\_\_\_  
\_\_\_\_\_

“Nays” \_\_\_\_\_

“Absent” \_\_\_\_\_

**PASSED** this 16th day of July, 2026.

\_\_\_\_\_  
Village Clerk

**APPROVED** this 14th day of July, 2026.

\_\_\_\_\_  
Village President

**CERTIFICATION OF ORDINANCE**

I, the undersigned, do hereby certify that I am the duly qualified and acting Village Clerk of the Village of Rantoul, Champaign County, Illinois (the “**Municipality**”), and that as such official I am the keeper of the records and files of the Municipality and its President and Board of Trustees.

I do further certify that the foregoing is a full, true and complete transcript of that portion of the minutes of the meeting of the President and Board of Trustees held on the 14th day of July, 2026, insofar as the same relates to the adoption of Ordinance 2834 entitled:

**AN ORDINANCE PROVIDING FOR AND REQUIRING THE SUBMISSION OF A BINDING REFERENDUM TO THE VOTERS OF THE VILLAGE OF RANTOUL, CHAMPAIGN COUNTY, ILLINOIS, AT THE GENERAL ELECTION TO BE HELD ON NOVEMBER 3, 2026 TO ABANDON ELECTION OF TRUSTEES BY DISTRICT AND THEREAFTER ELECT TRUSTEES ON A VILLAGE WIDE BASIS**

A true, correct and complete copy of which Ordinance as adopted at said meeting appears in the foregoing transcript of the minutes of such meeting.

I do further certify that the deliberations of the President and Board of Trustees on the adoption of such Ordinance were conducted openly, that the vote on the adoption of such Ordinance was taken openly, and was preceded by a public recital of the matter being considered and such other information as would inform the public of the business being conducted, that such meeting was held at a specified time and place convenient to the public, that notice of such meeting was duly given to all of the news media requesting such notice, that the agenda for such meeting was duly posted on the Municipality’s website, and at the Municipality’s offices at least 48 hours before the meeting, that such meeting was called and held in strict compliance with the provisions of the open meetings laws of the State of Illinois, as amended, and with the provisions of the Illinois Municipal Code of the State of Illinois, as amended, and that the President and Board of Trustees has complied with all of its procedural rules and the Open Meetings Act.

There is hereby certified to the County Clerk of the County of Champaign, Illinois for submission to the voters of the Municipality at the consolidated election to be held on the third day of November, 2026, the binding referendum set forth in such Ordinance: “**Shall the Village of Rantoul abandon the method of electing trustees from districts so that trustees shall be hereafter elected on a Village-wide basis?**,” which Ordinance was duly adopted by the President and Board of Trustees on the 14 day of July, 2026.

**IN WITNESS WHEREOF**, I hereunto affix my official signature, this 14th day of July, 2026.

(SEAL)

\_\_\_\_\_  
Janet E. Gray, Village Clerk

**Receipt**

The Champaign County Clerk hereby acknowledges receipt of the above Ordinance and binding referendum this \_\_\_\_ day of \_\_\_\_\_, 2026, and agrees to submit such binding referendum as herein and therein provided.

\_\_\_\_\_  
Champaign County Clerk

**BOARD OF TRUSTEES  
VILLAGE OF RANTOUL**

**AGENDA ITEM**

<p>ITEM: Resolution Authorizing an Advisory Referendum on the November 3, 2026 Election Ballot asking, "Shall the Village of Rantoul allow Cannabis Establishments to locate and operate within the Village?"</p>	<p>DEPARTMENT: Administration</p>
<p>DATE: July 7, 2026</p>	<p>AMOUNT:</p>
<p>ATTACHMENTS:</p> <p>1. 07-26-1457 Resolution - Advisory Referendum - Cannabis Businesses</p>	<p>ADMINISTRATIVE NOTES:</p>
<p>SUMMARY HIGHLIGHTS: At the request of Trustees, the Board is being asked to approve a Resolution seeking to put an advisory referendum on the ballot for the general election on November 3rd, 2026 for the voters to decide whether the Village should allow cannabis businesses to locate and operate within the Village. The Board would ONLY be voting to approve the placement of the referendum on the ballot, NOT the actual decision on whether to allow cannabis businesses to locate and operate within the Village.</p>	
<p>RECOMMENDED ACTION:</p>	
<p>DEPARTMENT HEAD APPROVAL Scott Eisenhauer</p>	<p>VILLAGE ADMINISTRATOR Scott Eisenhauer</p>

**RESOLUTION 07-26-1457**

**A RESOLUTION  
PROVIDING FOR AND REQUIRING THE SUBMISSION OF AN  
ADVISORY REFERENDUM TO THE VOTERS OF THE VILLAGE OF RANTOUL,  
CHAMPAIGN COUNTY, ILLINOIS, AT THE GENERAL ELECTION TO BE HELD  
ON NOVEMBER 3, 2026 CONCERNING ALLOWING CANNABIS BUSINESSES  
TO LOCATE AND OPERATE WITHIN THE VILLAGE OF RANTOUL**

**WHEREAS**, the Village of Rantoul, Champaign County, Illinois (the “**Municipality**”), is a Home Rule municipality under Article VII, Section 6, of the 1970 Constitution of the State of Illinois; and,

**WHEREAS**, the Corporate Authorities have previously voted to prohibit cannabis businesses from locating and operating within the village; and,

**WHEREAS**, the President and Board of Trustees (the “Corporate Authorities”) have been asked to adopt a Resolution seeking to put an advisory referendum on the ballot for the general election to be held on November 3, 2026 on whether the Village should allow cannabis businesses to locate and operate within the village.

**NOW, THEREFORE, BE IT AND IT IS HEREBY RESOLVED BY THE PRESIDENT AND BOARD OF TRUSTEES OF THE VILLAGE OF RANTOUL, CHAMPAIGN COUNTY, ILLINOIS**, as follows:

**Section 1. Whether to allow cannabis businesses to locate within the Village of Rantoul.** That the following Advisory Referendum be submitted to the voters of the Village of Rantoul: “Shall the Village of Rantoul allow cannabis businesses to locate and operate within the Village.”

**Section 2. Election.** That the Advisory Referendum hereinabove referred to be submitted to the voters of the Municipality in accordance with the general election law at the general election to be held on Tuesday, the third day of November, 2026, between the hours provided by law for voting on such day (the “**Election**”).

**Section 3. Election Precincts.** That the Election shall be held in the voting precincts and at the polling places established by the County Board (the “**County Board**”) of the County of Champaign, Illinois (the “**County**”), for voters of the Municipality at the Election.

**Section 4. Notice.** That the County Clerk of the County (the “**County Clerk**”) shall give notices of the Election in accordance with the general election law by publishing notice thereof at least once in one or more local, community newspapers published in or having general circulation in the Municipality, the date or dates of such publications of such notices to be not more than 30 nor less than 10 days prior to the date set for the Election, and otherwise in compliance with the applicable election law.

**Section 5. Newspapers.** That the local, community newspapers published in or having general circulation in the Municipality, and the newspaper published in or having general circulation in the County, related to the Election shall be as required by the Election Code of the State of Illinois, as amended (the “**Election Code**”).

**Section 6. Form of Notice.** That the notices of the Election shall include substantially the following (provided that this shall be deemed modified to conform with applicable law):

**NOTICE IS HEREBY GIVEN** that at the general election to be held on Tuesday, the third day of November, 2026, the following Advisory Referendum (modified as may be necessary to comply with applicable law) will be submitted to the voters of the Village of Rantoul, Champaign County, Illinois (The following may be modified to comply with applicable law.):

Shall the Village of Rantoul allow cannabis businesses to locate and operate within the Village?

The polls at such election will be open at 6:00 o'clock A.M. and continued open until 7:00 o'clock P.M. of that day.

Dated this \_\_\_\_ day of \_\_\_\_\_, 2026.

(facsimile Signature) \_\_\_\_\_  
County Clerk,  
County of Champaign, Illinois

**Section 7. Election.** That the ballot to be used at the Election shall be in substantially the following form with such alterations, changes, insertions, and deletions as required by applicable law, including Article 24A of the Election Code if an electronic, mechanical or electric voting system (an “**Electronic Voting System**”) is used at the Election:

(Face of Ballot)

**OFFICIAL BALLOT**

**ADVISORY REFERENDUM CONCERNING ALLOWING CANNABIS BUSINESSES TO LOCATE AND OPERATE WITHIN THE VILLAGE OF RANTOUL**

**(INSTRUCTIONS TO VOTERS: Punch opposite the word “YES” or “NO” to indicate your choice.)**

Shall the Village of Rantoul allow cannabis businesses to locate and operate within the Village?

YES  
: \_\_\_\_\_ :  
NO

---

(Back of Paper Ballot)

OFFICIAL BALLOT

Official ballot for voting on the Advisory Referendum concerning allowing cannabis businesses to locate and operate in the Village of Rantoul, Champaign County, Illinois, at the general election held on November 3, 2026.

Precinct Number: \_\_\_\_\_

Polling Place: \_\_\_\_\_  
\_\_\_\_\_  
\_\_\_\_\_

(Facsimile Signature)  
County Clerk, The County of  
Champaign, Illinois

**Section 8. Electronic Voting.** That, if an Electronic Voting System is used in the County, the County Clerk shall publish, not less than five (5) days prior to the Election, a true and legible copy of the specimen ballot label containing the question to be voted upon at the Election in two or more newspapers published in or having general circulation in the County.

**Section 9. Judges.** That the Election shall be conducted by the election judges appointed by the County Board to act in the precincts at which such proposition will be submitted to the voters of the Municipality.

**Section 10. Certify to County Clerk.** That immediately after the adoption hereof, the Village Clerk shall certify a copy hereof to the County Clerk in order that the Advisory Referendum set forth herein may be submitted to the voters of the Municipality at the Election.

**Section 11. Canvass.** That the Election shall be held and conducted and the returns thereof duly canvassed, all in the manner and time as provided by the general election law.

**Section 12. Conflict.** That all resolutions and parts of resolutions in conflict herewith be and the same are hereby repealed, that this resolution be in full force and effect forthwith upon its adoption and that this resolution shall be deemed to be subject to modification in application to comply with the general election law.

This Resolution is hereby passed, the “ayes” and “nays” being called, by the concurrence of a majority of the members of the Corporate Authorities then holding office at a meeting held on the date set forth below.

Upon motion by \_\_\_\_\_, seconded by \_\_\_\_\_, adopted this 14th day of July, 2026 upon a roll call vote as follows:

“Ayes” \_\_\_\_\_  
\_\_\_\_\_

“Nays” \_\_\_\_\_

“Absent” \_\_\_\_\_

**PASSED** this 16th day of July, 2026.

\_\_\_\_\_  
Village Clerk

**APPROVED** this 14th day of July, 2026.

\_\_\_\_\_  
Village President

**CERTIFICATION OF ORDINANCE**

I, the undersigned, do hereby certify that I am the duly qualified and acting Village Clerk of the Village of Rantoul, Champaign County, Illinois (the “**Municipality**”), and that as such official I am the keeper of the records and files of the Municipality and its President and Board of Trustees.

I do further certify that the foregoing is a full, true and complete transcript of that portion of the minutes of the meeting of the President and Board of Trustees held on the 14th day of July, 2026, insofar as the same relates to the adoption of Resolution 07-26-1457 entitled:

**A RESOLUTION  
PROVIDING FOR AND REQUIRING THE SUBMISSION OF AN  
ADVISORY REFERENDUM TO THE VOTERS OF THE VILLAGE OF RANTOUL,  
CHAMPAIGN COUNTY, ILLINOIS, AT THE GENERAL ELECTION TO BE HELD  
ON NOVEMBER 3, 2026 CONCERNING ALLOWING CANNABIS BUSINESSES  
TO LOCATE AND OPERATE WITHIN THE VILLAGE OF RANTOUL**

A true, correct and complete copy of which Resolution as adopted at said meeting appears in the foregoing transcript of the minutes of such meeting.

I do further certify that the deliberations of the President and Board of Trustees on the adoption of such Resolution were conducted openly, that the vote on the adoption of such Resolution was taken openly, and was preceded by a public recital of the matter being considered and such other information as would inform the public of the business being conducted, that such meeting was held at a specified time and place convenient to the public, that notice of such meeting was duly given to all of the news media requesting such notice, that the agenda for such meeting was duly posted on the Municipality’s website, and at the Municipality’s offices at least 48 hours before the meeting, that such meeting was called and held in strict compliance with the provisions of the open meetings laws of the State of Illinois, as amended, and with the provisions of the Illinois Municipal Code of the State of Illinois, as amended, and that the President and Board of Trustees has complied with all of its procedural rules and the Open Meetings Act.

There is hereby certified to the County Clerk of the County of Champaign, Illinois for submission to the voters of the Municipality at the consolidated election to be held on the third day of November, 2026, the advisory referendum set forth in such Resolution: “**Shall the Village of Rantoul allow cannabis businesses to locate and operate within the Village?**,” which Resolution was duly adopted by the President and Board of Trustees on the 14 day of July, 2026.

**IN WITNESS WHEREOF**, I hereunto affix my official signature, this 14th day of July, 2026.

(SEAL)

\_\_\_\_\_  
Janet E. Gray, Village Clerk

**Receipt**

The Champaign County Clerk hereby acknowledges receipt of the above Resolution and advisory referendum this \_\_\_\_ day of \_\_\_\_\_, 2026, and agrees to submit such advisory referendum as herein and therein provided.

\_\_\_\_\_  
Champaign County Clerk

**BOARD OF TRUSTEES  
VILLAGE OF RANTOUL**

**AGENDA ITEM**

ITEM: Notice Regarding the Hap Parker Family Aquatic Center	DEPARTMENT: Administration
DATE: July 7, 2026	AMOUNT:
ATTACHMENTS:	ADMINISTRATIVE NOTES:
SUMMARY HIGHLIGHTS:	
RECOMMENDED ACTION:	
DEPARTMENT HEAD APPROVAL Luke Humphrey	VILLAGE ADMINISTRATOR Scott Eisenhauer

**BOARD OF TRUSTEES  
VILLAGE OF RANTOUL**

**AGENDA ITEM**

ITEM: Discussion of Parliamentary Procedure: Robert's Rules of Order / Village of Rantoul Rules of Order	DEPARTMENT: Administration
DATE: July 7, 2026	AMOUNT:
ATTACHMENTS:  1. Village Board of Trustees Rules of Order	ADMINISTRATIVE NOTES:
SUMMARY HIGHLIGHTS:	
RECOMMENDED ACTION:	
DEPARTMENT HEAD APPROVAL	VILLAGE ADMINISTRATOR Scott Eisenhauer



## VILLAGE OF RANTOUL BOARD OF TRUSTEES

### RULES OF ORDER

#### **RULE I – QUORUM: ORDER OF BUSINESS**

The “Village Board” shall consist of the Village President and Trustees. A quorum for the transaction of business shall consist of a majority of all the members of the Village Board entitled by law to be elected.

When a quorum is physically present at a regular meeting, the Village Board shall proceed to the business before it, which shall generally be conducted in the following order:

- A. Call to Order
- B. Roll Call of Members
- C. Approval of Agenda
- D. Public Participation
- E. Reports of Village Officers
- F. Approval of bills and monthly financial reports
- G. Approval of Minutes of the proceedings of the previous meeting or meetings, with amendment of the same, *if applicable*
- H. Consideration of Contracts, Resolutions, and Ordinances
- I. New Business for Discussion
- J. General Announcements
- K. Adjournment

No member of the Village Board shall be prohibited from addressing the Village Board on a matter of business by the order of business adopted. The order of business may be altered or amended by the Village President from time to time, as the Village President determines necessary or desirable.

#### **RULE II – REMOTE PARTICIPATION PROHIBITED**

No member of the Village Board who is unable to be physically present at any meeting or study session shall be permitted to cast any votes, or participate in the discussion of items of business before the Village Board via electronic, telephonic, or any other alternative means of communication.

#### **RULE III – PRESIDING OFFICER**

The term “Presiding Officer” shall refer to the Village President, and in the absence of the Village President, shall apply equally to the President Pro Tempore. In the absence of both the President and President Pro Tempore, the term shall apply to the temporary Presiding Officer elected by the members of the Village Board.

In the absence of the Village President and President Pro Tempore, the Village Clerk shall call the proceeding to order, whereupon a temporary Presiding Officer shall be elected by the majority vote of the members of the Village Board present as the first order of business. Upon the arrival of the Village President or President Pro Tempore, the temporary Presiding Officer shall relinquish the Chair at the conclusion of the item of business then before the board.

The Village President may vote only where Statutes or Ordinances of the Village require more than a majority vote of the Village Board in the event of a tie, or where one-half of the Trustees elected have voted in favor of an Ordinance, Resolution, or motion, even though there is no tie vote.

#### **RULE IV – DUTIES OF PRESIDING OFFICER**

The Presiding Officer shall preside and act as the Chair at all regular and special meetings and study sessions of the Village Board. The Presiding Officer shall preserve order and decorum and may speak to points of order in preference to other members of the Village Board, and shall decide all questions of order subject to appeal. The Presiding Officer may speak to matters being considered by the Village Board without relinquishing the Chair. If the Presiding Officer refuses to allow any Trustee to exercise the right to appeal a decision of the Presiding Officer, the Trustees may consider and pass upon the matter in spite of the Presiding Officer's failure to grant them an appeal. In case of any disturbances or disorderly conduct, the Presiding Officer shall have the power to require the Chamber to be cleared.

Every Trustee, prior to speaking, making a motion or seconding the same, shall address the Presiding Officer, and shall not proceed with the remarks until recognized and named by the Presiding Officer. The recognized speaker shall limit the remarks to the question under debate avoiding personalities, and refraining from impugning the motives of any other Trustee's argument or vote. When two or more Trustees address the Presiding Officer at the same time, the Presiding Officer shall name the Trustee who is first to speak.

The President Pro Tempore or temporary Presiding Officer, when acting as Presiding Officer, shall vote on all questions on which the vote is taken by yeas and nays, with his or her name being called last by the Village Clerk.

#### **RULE V – MOTIONS GENERALLY**

A motion is a formal statement by a member of the Trustees of a proposal or question to the Village Board for consideration and action. No motion shall be debated or otherwise acted upon by the Village Board unless it has received an appropriate second, or unless otherwise provided in these rules. No further action is required on a motion which does not receive a second. Neither the maker nor the seconder of a motion shall be required to vote in favor of that motion.

If a question under consideration contains more than one distinct proposition, it may be divided upon the request of any of the Trustees.

When a motion is made and seconded, it shall be restated by the Presiding Officer before a vote is taken.

A motion, once before the Village Board, may not be withdrawn by the maker without the consent of the seconder.

## **RULE VI – VOTING**

When the Village Clerk has commenced to call roll of the Village Board for the taking of a vote, all debate on the question before the Village Board shall be deemed concluded. During the taking of the vote, a member shall be permitted to briefly explain his or her vote, and shall respond to the call of his or her name by the Village Clerk by answering “yea” or “nay” as the case may be.

The Village Clerk shall begin taking any roll call vote with the Trustee by whom the pending motion has been made, then by calling the name of the Trustee seated immediately to his or her left, and continuing to call the names of the remaining Trustees in like fashion until all names have been called and answered. The Presiding Officer shall always be the last member to voice his or her vote, if authorized.

A roll call vote shall be required for the following:

- A. All Resolutions or motions to create an office or a position of employment, to create any liability against the Village, to incur any expenditure, or to appropriate money;
- B. All Ordinances;
- C. Approval by Omnibus vote of any items listed under the Consent Agenda

The Presiding Officer may utilize a voice vote for any other matters where a roll call vote is not required by law; provided, however, that a roll call vote shall be taken upon the timely request of any Trustee.

A vote lacking the required number of affirmative votes shall constitute defeat of the motion under consideration.

A Trustee may change his or her vote only if a timely request to do so is made prior to the announcement of the vote by the Presiding Officer.

Every Trustee who shall be present when a question is stated from the Presiding Officer shall vote thereon unless excused by the other members of the Village Board.

Where the temporary absence of a members of the Village Board during the course of a convened meeting results in a lack of quorum, the matter then under consideration shall be considered as having been postponed until the next regular meeting. The meeting may continue after the postponement has been announced by the Presiding Officer and the member breaking the quorum has resumed his or her presence; otherwise the Presiding Officer shall declare the meeting adjourned after such announcement.

The Presiding Officer shall announce the vote on every matter upon which a vote is taken, and a vote on any matter shall not be effective until announced by the Presiding Officer.

## **RULE VII – CONSIDERATION FOR FINAL ACTION**

No item on the agenda of a regular meeting of the Village Board shall be considered for final action at such regular meeting unless: (i) such item was presented and discussed at any prior regular or special meeting or study session of the Village Board; (ii) such item was presented and discussed in a written report or memorandum received by the members of the Village Board at least 48 hours prior to such regular meeting; or (iii) such item is retained on the agenda for final action by the

affirmative vote of not less than a majority of the members of the Village Board who are present and voting.

### **RULE VIII – CONSIDERATION OF ITEMS BY OMNIBUS VOTE**

The Village Clerk, or his or her designee, in preparing the agenda for any regular meeting, may include regular, recurring or routine matters under the heading of “Consent Agenda” provided that the inclusion of any items under this heading shall first be authorized by the Village President or the Village Administrative Officer. No item requiring greater than a majority vote shall be placed upon the Consent Agenda.

Any member of the Village Board may request that an item or items be removed from the proposed Consent Agenda for the purpose of additional discussion, debate, or separate vote. Upon such request, the item or items shall be removed from the Consent Agenda and shall be considered, debated, and voted upon separately as the next items of business immediately following a vote upon the Consent Agenda. Action may be taken on all items remaining on the Consent Agenda by a single motion made, seconded and adopted by roll call vote of those members of the Village Board present. The taking of an omnibus vote on the items listed upon the Consent Agenda shall for all intents and purposes, and with the like effect, be as if the vote in each case had been taken separately by yeas and nays, and separately recorded in the journal.

### **RULE IX – REQUESTS TO ADDRESS THE BOARD: PUBLIC PARTICIPATION**

Members of the public shall be permitted to address the Village Board during a designated portion of each regular meeting, regular study session, and special meeting, to comment on any matters of public concern of Village Business.

No person shall address the Village Board without having first secured the recognition of the Presiding Officer.

Each member of the public addressing the Village Board shall be limited to three minutes for his or her presentation, unless authorized to receive additional time by the consent of a majority of the Village Board present. The Village Clerk, or in his or her absence the Deputy Village Clerk, shall be designated as official timekeeper, and shall be responsible for notifying the Presiding Officer when the allotted time for each speaker has expired. In the absence of both the Village Clerk and Deputy Village Clerk, the Village Board shall designate another Village employee or officer to serve as timekeeper. The total time allotted to “public participation” in a meeting will be 30 minutes, unless additional time is authorized by the consent of a majority of the Village Board present.

Each member of the public addressing the Board shall be expected to conform to conventional standards of decorum.

Only the Presiding Officer shall have the authority to request that a speaker suspend his or her remarks for exceeding the prescribed time limit or for any other reason

Each member of the public, before addressing the Village Board shall be required to sign in with the Village Clerk before the meeting is called to Order. Members of the public may comment on any matters of public concern or Village business at each regular study session and regular meeting. Comments from the public at a special meeting shall be limited in scope to only those matters of

business then under imminent consideration by the Village Board at that special meeting.

Other than during the designated period provided for public participation, the Village Board shall follow the prepared agenda. The members of the Village Board shall enter into the discussion of agenda items in a manner which permits other members of the Village Board, Village staff, and members of the public to hear the proceedings of the Village Board, but shall refrain from interaction with members of the public during business sessions. The Presiding Officer may, in his or her discretion, call on members of the public for information which may assist the Village Board in consideration of any agenda item.

## **RULE X – MINUTES: DOCUMENTS**

Minutes of all meetings and study sessions shall be permanently recorded in the form of a journal. Such Minutes shall be prepared and maintained by the Office of the Village Clerk and shall include the following:

- A. The date, time, and location of the meeting or study session
- B. The members recorded as either physically present or absent
- C. A general summary of all matters proposed, discussed or decided
- D. A record of any and all votes taken

The Minutes of all meetings and study sessions shall be approved by the vote of the Village Board at the following regular meeting. Reading of the Minutes shall not be necessary prior to approval, provided that the Village Clerk has provided each member with a copy of the drafted minutes in advance of the meeting. The Minutes may be revised at any time by the Village Clerk to correct spelling, grammar, numbering, or other such technical defects. Prior to approval, any members of the Village Board may, through the Presiding Officer, request the privilege of amending or correcting the Minutes for the purpose of maintaining truth and accuracy in the journal of the Village Board. If objection is made by any member of the Village Board to such amendment or correction, a majority vote of the Village Board shall be necessary for adoption of the correction or amendment.

The Village Clerk shall attest to the passage of all Ordinances and Resolutions by his or her signature, and shall affix the seal of the Village of Rantoul to all such documents. In the absence of the Village Clerk, the Deputy Village Clerk shall be authorized to sign the name of the Village Clerk on any of the aforementioned documents.

## **RULE XI – APPROVE OR VETO**

All Ordinances of whatever kind, and any Resolution or motion creating any liability against the Village or providing for the expenditure or appropriation of its money, or the sale of Village property, shall be deposited with the Village Clerk, and if the Village President approves thereof, the Village President shall sign the same, and such as are not approved shall be returned to the Village Board with objections thereto in writing at the next regular meeting of the Village Board occurring not less than five days after the passage thereof. Such veto may extend to any one or more items or appropriations contained in any Ordinance making an appropriation, or to the entire Ordinance; and in case the veto only extends to a part of such Ordinance, the residue thereof shall take effect and be in force. But in case the Village President shall fail to return any Ordinance with his or her objections thereto by the time aforesaid, such Ordinances shall become effective despite the absence of the Village President's signature.

Upon the return of any Ordinance by the Village President, the vote by which the same was passed may be reconsidered by the Village Board at its next regular meeting after the return of the veto; and if, after such reconsideration, two-thirds of all the Trustees then holding office shall agree, by yeas and nays, to pass the same, it shall go into effect notwithstanding the Village President's veto.

## **RULE XII – VERBATIM RECORDING OF OPEN MEETINGS**

A verbatim recording of the proceedings of each open meeting and study session of the Village Board shall be prepared and maintained by the office of the Village Clerk, and shall be made available for public inspection or copying upon request. The verbatim recording of each open meeting or study session shall be maintained by the Village for a period of not less than four years from the date of the approval of the official Minutes of the respective meeting or study session. After the retention period is concluded, the Village Clerk, or his or her designee may, with the approval of the Village Board, petition the Local Records Commission of the State of Illinois for authorization to destroy or otherwise dispose of those verbatim recordings.

The Village Board may from time to time determine that the verbatim recordings of particular meetings or study sessions hold significant historical value and may direct the Village Clerk to extend the retention period for such records accordingly.

## **RULE XIII – CLOSED SESSIONS: MINUTES AND RECORDINGS**

The Village Clerk, or his or her designee, shall keep and maintain written Minutes of all closed session meetings of the Village Board as defined by the Illinois Open Meetings Act as now existing or as hereafter amended. The Minutes of closed session meetings shall be reviewed and approved periodically by the Village Board in closed session; provided that such review occurs not less frequently than once every six months. Minutes of closed session meetings shall be made available to the public only after the Board has determined that it is no longer necessary to protect the public interest or the privacy of an individual. Any vote to authorize the public release of closed session Minutes shall be taken openly by the Village Board in the form of a Resolution.

In addition to written Minutes, the Village Clerk or his or her designee, shall keep and maintain a verbatim recording of all closed session proceedings. The Office of the Village Clerk shall be responsible for maintaining the recording equipment and a sufficient amount of cassette tapes or other recording materials as necessary to comply therewith.

The Village Clerk shall be responsible for maintaining all verbatim recordings of closed session meetings until such time that they are authorized for destruction by resolution of the Village Board in accordance with the Illinois Open Meetings Act. The verbatim recordings and the separate journal of closed session shall be maintained in a secure file, which may only be accessed by the Village Clerk, or such personnel as may be authorized by the Village Clerk.

The Minutes and verbatim recordings of all closed session meetings shall be made available for inspection of any member of the Village Board; provided that such inspection is made in the presence of the Village Clerk, or his or her designee. Duplicate copies of verbatim recordings or Minutes of closed session meetings shall not be produced for any member without the specific authorization of the Village Board.

## **RULE XIV – EXPULSION OF MEMBERS**

Any member of the Village Board acting or appearing in a disgraceful manner, or who uses opprobrious or insulting language to or about any other member of the Village Board, or who does not obey the order of the Presiding Officer, shall be, on motion, censured by a majority vote of the members of the Village Board present, or expelled by a two-thirds vote of all members of the Village Board elected. No member of the Village Board may be expelled a second time for the same incident.

## **RULE XV – SUSPENSION OF RULES**

These rules may be temporarily suspended by a vote of two-thirds of the Trustees present, except in cases where suspension of these rules would result in the violation of federal or state Statutes or local Ordinances. These rules shall not be repealed, altered, or amended unless notice thereof shall have been in writing, and the alteration and amendment submitted is at least one meeting prior thereto the two-thirds of the Trustee shall concur therein.

## **RULES XVI – ADOPTION OF ROBERT’S RULES OF ORDER REVISED**

The Rules of Parliamentary Procedure comprised in the latest published edition of “Robert’s Rules of Order Revised” shall govern the Village Board in all cases to which they are applicable, and in which they are not inconsistent with these rules or the statutes and laws of the State of Illinois.

## **RULE XVII – FAILURE TO OBSERVE PROCEDURES**

These Rules of Order of the Village Board, and the procedures contained herein, are adopted to expedite the transaction of business of the Village Board in an orderly fashion, and they are deemed to be procedural in nature only. Any failure to strictly observe these Rules of Order by the Village Board shall not affect the jurisdiction of the Village Board, nor shall it serve to invalidate any action taken at a meeting that is otherwise held in conformity with applicable law.

**BOARD OF TRUSTEES  
VILLAGE OF RANTOUL**

**AGENDA ITEM**

<p>ITEM: <b>Senior Swim - Free!</b> July 10th - 17th - 24th   Noon-1:00pm Hap Parker Family Aquatic Center</p>	<p>DEPARTMENT: Administration</p>
<p>DATE: July 7, 2026</p>	<p>AMOUNT: N/A</p>
<p>ATTACHMENTS:  1. Senior Brochure 2026</p>	<p>ADMINISTRATIVE NOTES:</p>
<p>SUMMARY HIGHLIGHTS:</p>	
<p>RECOMMENDED ACTION:</p>	
<p>DEPARTMENT HEAD APPROVAL Luke Humphrey</p>	<p>VILLAGE ADMINISTRATOR Scott Eisenhauer</p>

# October:

## Covered Bridge Festival

- Date and time to be determined  
\$\$\$ registration is required

# November:

## Festival of Trees

- Date and time to be determined  
\$\$\$ registration is required

## Coffee and Conversations

- Every Tuesday Morning in November from 10 a.m. to 11 a.m.
- Recreation Building  
**Free**, but registration is encouraged

# December:

## Senior Lunch

- December 10th at 11:30 a.m.
- Rantoul Youth Center  
**Free**, but registration is encouraged

## Trip to Fashion Mall at Keystone Carmel, Indiana

- Date and time to be determined  
\$\$\$ registration is required

## Brochure Key :

**\$\$\$ registration is required** – a cost is associated with this activity and registration is required!

**FREE**– No cost or registration is required!

**FREE but registration is encouraged** – While this activity has no cost associated, we would appreciate if you could give our office a call to let us know you are coming.

## To our Rantoul Seniors:

Thank you for your involvement in our community! We would not be where we are without each and every one of you. One of our goals at the Rantoul Recreation Department is to provide our Rantoul Seniors with engaging activities and events, and your participation allows us to continue this programming. If you want to stay up to date about upcoming programs, give us a call to get signed up for notifications.

## Contact us:

Recreation Office : (217) 893-5700  
Phoenix LaCombe : (217) 893-5771  
Maggie Bowen : (217) 893-5703

Ask us how to sign up for Senior Programming reminders!

**RANTOUL**  
Parks & Recreation

## 2026 Activity Guide

## Rantoul Senior Programming



# January

No Events or Trips  
Planned for January



# April

## The Pottery Place

- Date and time to be determined  
**\$\$\$** registration is required

# July

## Senior Swim

- Every Friday in July from 12:00 p.m. to 1:00 p.m.  
**Free** but must stop at the front desk before entering the pool deck

## Senior Lunch

- July 16<sup>th</sup> at 11:30 a.m.
- Recreation Building  
**Free**, but registration is encouraged



# February

## Casino Trip

- Date, time, and location to be determined  
**\$\$\$** registration is required

# May

## Senior Luncheon

- May 21st at 11:30 a.m.
- Recreation Building  
**FREE**, but registration is encouraged

# August

## Festival Trip

- Date, time, and festival to be determined  
**\$\$\$** registration is required

# March

## Senior Luncheon

- March 19th at 11:30 a.m.
- Recreation Building  
**FREE**, but registration is encouraged



# June

## Senior Swim

- Every Friday in June from 12:00 p.m. to 1:00 p.m.  
**Free**, but must stop at the front desk before entering the pool deck

# September

## Senior Lunch

- September 17<sup>th</sup> at 11:30 a.m.
- Rantoul Family Sports Complex  
**Free**, but registration is encouraged



**BOARD OF TRUSTEES  
VILLAGE OF RANTOUL**

**AGENDA ITEM**

<p><b>ITEM: Freedom Fridays Event Series   6-9:00pm</b>          July 10 at the Rantoul Family Sports Complex with the Tom Grassman Band          July 17 at the Fringe with Vivacious Audio          July 24 in Downtown Rantoul with 90's Daughter</p>	<p>DEPARTMENT: Recreation</p>
<p>DATE: July 7, 2026</p>	<p>AMOUNT: Free!</p>
<p>ATTACHMENTS:           1. Freedom Fridays</p>	<p>ADMINISTRATIVE NOTES:</p>
<p>SUMMARY HIGHLIGHTS:</p>	
<p>RECOMMENDED ACTION:</p>	
<p>DEPARTMENT HEAD APPROVAL          Luke Humphrey</p>	<p>VILLAGE ADMINISTRATOR          Scott Eisenhauer</p>

*July 3rd*

Hap Parker Family Aquatic Center with...



# Freedom Fridays

*July 10th*

Rantoul Family Sports Complex with...



2026 Event Series  
Rantoul

6pm to 9pm

*July 17th*

The Fringe with...



*July 24th*

Downtown with...



90's Daughter Sponsored By:

MAVERICK  PIPE

**BOARD OF TRUSTEES  
VILLAGE OF RANTOUL**

**AGENDA ITEM**

<p>ITEM: <b>Congresswoman Robin Kelly / IL State Senator Paul Faraci</b>          Mobile Office Hours   July 8 1:00-4:00pm          Rantoul Business Center</p>	<p>DEPARTMENT: Administration</p>
<p>DATE: July 7, 2026</p>	<p>AMOUNT:</p>
<p>ATTACHMENTS:</p> <p>1. Mobile Office Hours 070826</p>	<p>ADMINISTRATIVE NOTES:</p>
<p>SUMMARY HIGHLIGHTS:</p>	
<p>RECOMMENDED ACTION:</p>	
<p>DEPARTMENT HEAD APPROVAL</p>	<p>VILLAGE ADMINISTRATOR          Scott Eisenhauer</p>

# MOBILE OFFICE HOURS

With the Office of Congresswoman Robin Kelly &  
the Office of Illinois State Senator Paul Faraci



## WHERE:

**Rantoul Business  
Center**

601 S Century Blvd.,  
Rantoul, IL 61866

## WHEN:

July 8th

1:00PM - 4:00PM

Staff from the Office of Congresswoman Robin Kelly & Illinois State Senator Paul Faraci will be on site to assist with federal & state issues.

**BOARD OF TRUSTEES  
VILLAGE OF RANTOUL**

**AGENDA ITEM**

<p><b>ITEM: Former Chanute Air Force Base Public Meeting</b>  Update on PFAS Actions &amp; Remedial Investigation  Wednesday, July 8 at 7:00pm  Louis B. Schelling Memorial Board Room</p>	<p>DEPARTMENT: Administration</p>
<p>DATE: July 7, 2026</p>	<p>AMOUNT:</p>
<p>ATTACHMENTS:</p> <ol style="list-style-type: none"> <li>1. AF Public Meeting 070826</li> <li>2. Chanute PFAS RI Fact Sheet July 2026</li> </ol>	<p>ADMINISTRATIVE NOTES:</p>
<p>SUMMARY HIGHLIGHTS:</p>	
<p>RECOMMENDED ACTION:</p>	
<p>DEPARTMENT HEAD APPROVAL</p>	<p>VILLAGE ADMINISTRATOR</p>



# STAY INFORMED!

## PUBLIC MEETING



### WHAT?

The Department of the Air Force is hosting a Public Meeting to update the Village of per- and polyfluoroalkyl substances (PFAS) actions at the former Chanute Air Force Base. Representatives will provide an overview, and answer questions regarding the response to PFAS, and the ongoing Remedial Investigation at the former base. The process aims to identify the nature and extent of PFAS contamination, and assess its risk to human health and the environment.

### WHEN?

Wednesday, July 8, 2026 at 7:00pm

### WHERE?

Rantoul Village Hall, Louis B. Schelling Board Room, 333 South Tanner Street, Rantoul, IL

### QUESTIONS?

Air Force Installation and Mission Support Public Affairs  
866-725-7617 | [AFIMSC.PA.Workflow@us.af.mil](mailto:AFIMSC.PA.Workflow@us.af.mil)

## FORMER CHANUTE AIR FORCE BASE

## Fact Sheet

### Former Chanute AFB PFAS Remedial Investigation Nearing Completion

**UPCOMING PUBLIC MEETING**

The next public meeting will be held at the Village Hall on Wednesday, July 8<sup>th</sup>, 2026, at 7 pm. The public meeting will be live streamed, and video will be available for viewing on the Village of Rantoul Facebook page. The Air Force will provide an update on the PFAS Remedial Investigation at Chanute.

#### Remedial Investigation at Former AFFF Areas

The Air Force is working closely with the Illinois Environmental Protection Agency to address Per- and Polyfluoroalkyl Substances (PFAS) due to historical use of aqueous film-forming foam (AFFF) at the former Chanute Air Force Base (AFB). Early evaluations confirmed PFAS in several areas such as fire training, fire demonstration, wastewater treatment plant, dredge spoils, and sewage sludge disposal, leading the Air Force to begin a comprehensive Remedial Investigation to understand the extent of impacts and any potential risks. Fieldwork for the investigation began in 2024 and will continue through 2027, focusing on defining where PFAS is located and how it may affect people and the environment.

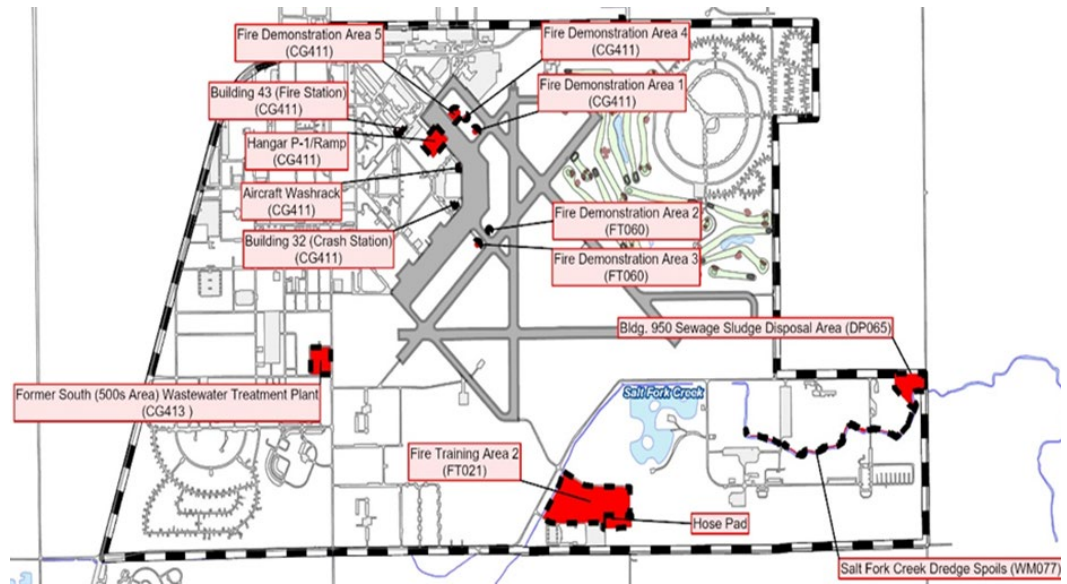

Figure 1: AFFF Areas

#### Progress Report

The Air Force has conducted five sampling mobilizations to define the nature and extent of PFAS due to historic AFFF use. In total, the Air Force has collected 648 groundwater samples and 983 soil samples, along with surface water, outfall, and sediment samples in Salt Fork Creek; sanitary sewer and storm sewer samples; and surface water samples from Heritage Lake.

As the investigation has progressed into Mobilization 5, sampling efforts have expanded to incorporate regulatory feedback and close remaining data gaps needed to evaluate potential risks to human health and the environment. PFAS impacts have been delineated at most of the AFFF areas, with only a few locations requiring additional sampling.

## Anthropogenic Background Study

The Air Force is also completing an Anthropogenic Background Study. This study helps determine whether low levels of PFAS found in the area come from everyday sources, such as consumer products, past light industrial activities, or regional conditions, rather than from the former base activities. To do this, samples were collected from locations that are far enough away from known Air Force PFAS release areas to make sure they aren't influenced by base-related activities. By comparing these samples to the results from the investigation areas, the study helps the Air Force understand which PFAS levels are part of anthropogenic background conditions in the former base.

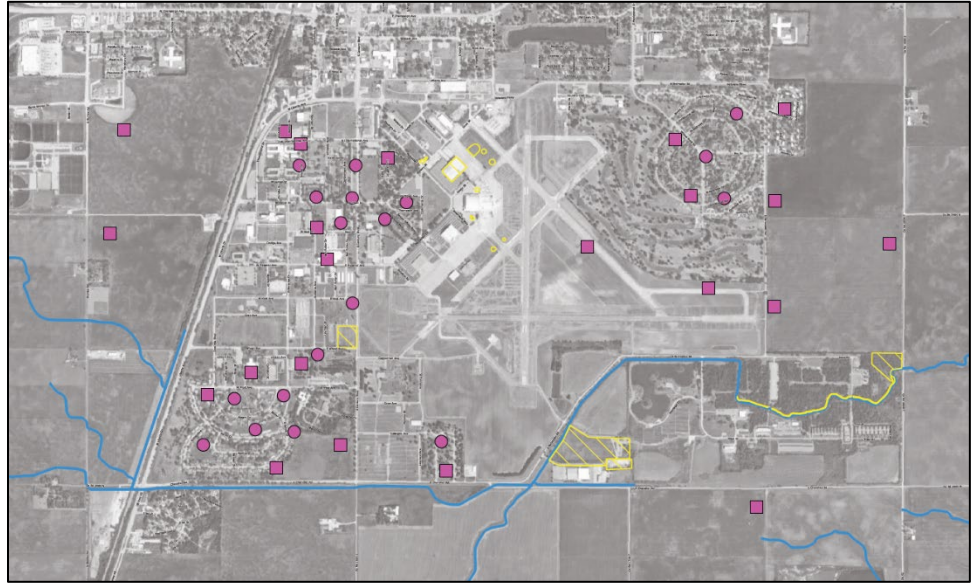
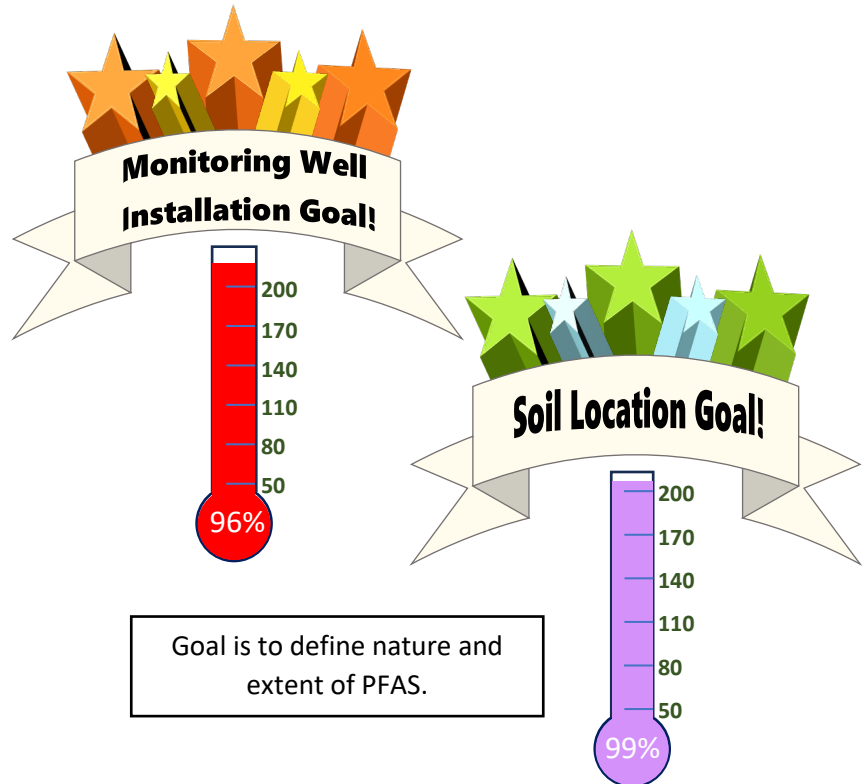

Figure 2: Anthropogenic Background Study Sample Locations

## Next Steps

The next mobilization will focus on completing delineation of PFAS at a few locations for groundwater and one location for soil. Additional studies, such as fish tissue sampling, are being incorporated into the remedial investigation in coordination with Illinois Environmental Protection Agency, out of abundance of caution, to ensure there are no impacts to the community or local ecosystems. Together, these remaining tasks will close out the sampling phase of the remedial investigation, after which evaluation of potential risks to human health and the environment will begin.



For more information, contact AFIMSC Public Affairs: 1-866-725-7615

AFIMSC.PA.workflow@us.af.mil | www.afimsc.af.mil

**BOARD OF TRUSTEES  
VILLAGE OF RANTOUL**

**AGENDA ITEM**

<p>ITEM: <b>EAA Young Eagles Rally &amp; Pancake Breakfast - FREE!</b>          July 11   9:00 - 11:00am          Rantoul National Aviation Center          Register at <a href="http://eaachapters.org">eaachapters.org</a></p>	<p>DEPARTMENT: Administration</p>
<p>DATE: July 7, 2026</p>	<p>AMOUNT:</p>
<p>ATTACHMENTS:</p> <p>1. Young Eagles Flyer 071126</p>	<p>ADMINISTRATIVE NOTES:</p>
<p>SUMMARY HIGHLIGHTS:</p>	
<p>RECOMMENDED ACTION:</p>	
<p>DEPARTMENT HEAD APPROVAL Bob Coverdill</p>	<p>VILLAGE ADMINISTRATOR Scott Eisenhauer</p>

# Welcome Young Eagles

Free Flights for Youths 8 to 17



## YOUNG EAGLES FLIGHT RALLY

Saturday, July 11, 2026 | 9:00 - 11:00am

Frank Elliott Field • Rantoul National Aviation Center

- ➔ Generously Sponsored by EAA Chapter 29
- ➔ Parent/Legal Guardian must be Present
- ➔ Introduction to the World of Aviation
- ➔ Achieve Young Eagle Certification
- ➔ Exploration of Career Pathways

PRE-REGISTRATION  
IS REQUIRED



JOIN US FOR A DAY OF FLYING FUN!

[www.eaachapters.org](http://www.eaachapters.org)

**BOARD OF TRUSTEES  
VILLAGE OF RANTOUL**

**AGENDA ITEM**

<p>ITEM: <b>Senior Luncheon</b>          Thursday, July 16   11:30am          Rantoul Recreation Building          Call 217-893-5703 to RSVP</p>	<p>DEPARTMENT: Administration</p>
<p>DATE: July 7, 2026</p>	<p>AMOUNT:</p>
<p>ATTACHMENTS:</p> <p>1. Senior Brochure 2026</p>	<p>ADMINISTRATIVE NOTES:</p>
<p>SUMMARY HIGHLIGHTS:</p>	
<p>RECOMMENDED ACTION:</p>	
<p>DEPARTMENT HEAD APPROVAL</p>	<p>VILLAGE ADMINISTRATOR</p>

# October:

## Covered Bridge Festival

- Date and time to be determined  
\$\$\$ registration is required

# November:

## Festival of Trees

- Date and time to be determined  
\$\$\$ registration is required

## Coffee and Conversations

- Every Tuesday Morning in November from 10 a.m. to 11 a.m.
- Recreation Building  
**Free**, but registration is encouraged

# December:

## Senior Lunch

- December 10th at 11:30 a.m.
- Rantoul Youth Center  
**Free**, but registration is encouraged

## Trip to Fashion Mall at Keystone Carmel, Indiana

- Date and time to be determined  
\$\$\$ registration is required

## Brochure Key :

**\$\$\$ registration is required** – a cost is associated with this activity and registration is required!

**FREE**– No cost or registration is required!

**FREE but registration is encouraged** – While this activity has no cost associated, we would appreciate if you could give our office a call to let us know you are coming.

## To our Rantoul Seniors:

Thank you for your involvement in our community! We would not be where we are without each and every one of you. One of our goals at the Rantoul Recreation Department is to provide our Rantoul Seniors with engaging activities and events, and your participation allows us to continue this programming. If you want to stay up to date about upcoming programs, give us a call to get signed up for notifications.

## Contact us:

Recreation Office : (217) 893-5700  
Phoenix LaCombe : (217) 893-5771  
Maggie Bowen : (217) 893-5703

Ask us how to sign up for Senior Programming reminders!

**RANTOUL**  
Parks & Recreation

## 2026 Activity Guide

## Rantoul Senior Programming



# January

No Events or Trips  
Planned for January



# April

## The Pottery Place

- Date and time to be determined  
**\$\$\$** registration is required

# July

## Senior Swim

- Every Friday in July from 12:00 p.m. to 1:00 p.m.  
**Free** but must stop at the front desk before entering the pool deck

## Senior Lunch

- July 16<sup>th</sup> at 11:30 a.m.
- Recreation Building  
**Free**, but registration is encouraged



# February

## Casino Trip

- Date, time, and location to be determined  
**\$\$\$** registration is required

# May

## Senior Luncheon

- May 21st at 11:30 a.m.
- Recreation Building  
**FREE**, but registration is encouraged

# August

## Festival Trip

- Date, time, and festival to be determined  
**\$\$\$** registration is required

# March

## Senior Luncheon

- March 19th at 11:30 a.m.
- Recreation Building  
**FREE**, but registration is encouraged



# June

## Senior Swim

- Every Friday in June from 12:00 p.m. to 1:00 p.m.  
**Free**, but must stop at the front desk before entering the pool deck

# September

## Senior Lunch

- September 17<sup>th</sup> at 11:30 a.m.
- Rantoul Family Sports Complex  
**Free**, but registration is encouraged



**BOARD OF TRUSTEES  
VILLAGE OF RANTOUL**

**AGENDA ITEM**

<p>ITEM: Motion to enter into closed session pursuant to 5 ILCS 120/2 (C) 2, to consider collective negotiating matters between the public body and its employees or their representatives, or deliberations concerning salary schedules for one or more classes of employees</p>	<p>DEPARTMENT: Administration</p>
<p>DATE: July 7, 2026</p>	<p>AMOUNT:</p>
<p>ATTACHMENTS:</p>	<p>ADMINISTRATIVE NOTES:</p>
<p>SUMMARY HIGHLIGHTS:</p>	
<p>RECOMMENDED ACTION:</p>	
<p>DEPARTMENT HEAD APPROVAL Chief Tony Brown</p>	<p>VILLAGE ADMINISTRATOR Scott Eisenhauer</p>

**BOARD OF TRUSTEES  
VILLAGE OF RANTOUL**

**AGENDA ITEM**

<p>ITEM: Motion to enter into closed session pursuant to 5 ILCS 120/2 (C) 1, to consider the appointment, employment, compensation, discipline, performance, or dismissal of specific employees, or legal counsel for the public body, including hearing testimony on a complaint lodged against an employee</p>	<p>DEPARTMENT: Administration</p>
<p>DATE: July 7, 2026</p>	<p>AMOUNT:</p>
<p>ATTACHMENTS:</p>	<p>ADMINISTRATIVE NOTES:</p>
<p>SUMMARY HIGHLIGHTS:</p>	
<p>RECOMMENDED ACTION:</p>	
<p>DEPARTMENT HEAD APPROVAL</p>	<p>VILLAGE ADMINISTRATOR</p>

**BOARD OF TRUSTEES  
VILLAGE OF RANTOUL**

**AGENDA ITEM**

<p>ITEM: Motion to enter into Closed Session pursuant to 5 ILCS 120/2 (C) 21, for the discussion of Minutes of meetings lawfully Closed under the Open Meetings Act, whether for the purposes of approval by the body of the Minutes or semiannual review of the Minutes as mandated</p>	<p>DEPARTMENT: Administration</p>
<p>DATE: July 7, 2026</p>	<p>AMOUNT:</p>
<p>ATTACHMENTS:</p> <p>1. Closed Minute Ledger 071426</p>	<p>ADMINISTRATIVE NOTES:</p>
<p>SUMMARY HIGHLIGHTS:</p>	
<p>RECOMMENDED ACTION:</p>	
<p>DEPARTMENT HEAD APPROVAL</p>	<p>VILLAGE ADMINISTRATOR</p>

**CLOSED MEETINGS**

**June 29, 2026**

<u>Res #</u>	<u>Date</u>	<u>Subject</u>	<u>Confidentiality Still Exists</u>	<u>To Be Released</u>
	Feb. 8, 1996	FOP negotiation matters	X	
	June 6, 1996	FOP negotiation matters	X	
	Sept. 25, 1996	Specific employee matter - Comptroller	X	
	Dec. 14, 1996	Specific employee matter - Administrator	X	
	Jan. 14, 1997	Specific employee matter - Administrator	X	
	Feb. 28, 1997	Specific employee matter - Administrator	X	
	June 3, 1997	FOP negotiation matters	X	
	July 1, 1997	FOP negotiation matters	X	
	Dec. 2, 1997	IBEW negotiation matters	X	
	Jan. 13, 1998	Specific employee matter - Elec. Supt.	X	
	May 12, 1998	IBEW negotiation matters	X	
81	Oct. 6, 1998	IBEW negotiation matters	X	
109	April 19, 1999	FOB Negotiations	X	
182	Sept. 12, 2000	FOB Negotiations	X	
210A	June 12, 2001	Specific employee matter - Exec. Sec.	X	
	March 5, 2002	Specific employee matter - Exec. Sec.	X	
242	March 18, 2002	Specific employee matter - Econ. Dev. Dir	X	
246	May 14, 2002	Specific employee matter - Fire Chief	X	
257	June 4, 2002	Specific employee matter - Fire Chief	X	
259	June 27, 2002	Specific employee matter - Econ. Dev. Dir	X	
268	August 26, 2002	IBEW negotiation matters	X	
270	Sept. 3, 2002	IBEW negotiation matters	X	
270	Dec. 3, 2002	Specific employee matter - IMS Manager	X	
280	Jan. 7, 2003	Specific employee matter-Computer Tech	X	
284	Feb. 4, 2003	Specific employee matter - IMS employee	X	
291	March 11, 2003	Specific employee matter - CD employee	X	
291	April 1, 2003	Specific employee matter - CD employee	X	
291	April 8, 2003	Specific employee matter - CD employee	X	
295	Nov. 4, 2003	FOP negotiation matters	X	
332	Feb. 3, 2004	FOP negotiation matters	X	
337	Feb. 17, 2004	FOP negotiation matters	X	
354	June 8, 2004	Specific employee matter - Econ. Dev. Dir	X	

<u>Res #</u>	<u>Date</u>	<u>Subject</u>	<u>Confidentiality Still Exists</u>	<u>To Be Released</u>
366	August 12, 2004	Specific employee matter - Administrator	X	
368	August 25, 2004	Special Board Meeting - Administrator	X	
370	August 25, 2004	Specific employee matter - Administrator	X	
370	Sept. 2, 2004	Specific employee matter - Administrator	X	
373	Sept. 7, 2004	Specific employee matter - Administrator	X	
374	Sept. 14, 2004	Specific employee matter - Administrator	X	
375	Sept. 14, 2004	Specific employee matter - Administrator	X	
485	Aug. 8, 2006	Specific employee matter - Econ. Dev. Dir	X	
493	Oct. 16, 2006	Specific employee matter - Econ. Dev. Dir	X	
494	Oct. 16, 2006	Specific employee matter - Econ. Dev. Dir	X	
495	Oct. 18, 2006	Specific employee matter - Econ. Dev. Dir	X	
496	Oct. 18, 2006	Specific employee matter - Econ. Dev. Dir	X	
497	Oct. 18, 2006	Specific employee matter - Econ. Dev. Dir	X	
499	Nov.2, 2006	Specific employee matter - Econ. Dev. Dir	X	
500	Nov.2, 2006	Specific employee matter - Econ. Dev. Dir	X	
502	Nov. 7, 2006	Specific employee matter - Attorney	X	
503	Nov. 13, 2006	Specific employee matter - Econ. Dev. Dir	X	
506	Dec. 5, 2006	Specific employee matter - Administrator	X	
509	Dec. 14, 2006	Appointment of legal counsel	X	
509	Dec. 14, 2006	Appointment of legal counsel	X	
511	Jan 2, 2007	Specific employee matter - Administrator	X	
516	Feb. 6, 2007	Specific employee matter - Econ. Dev. Dir	X	
524	March 13, 2007	Specific employee matter - Administrtror	X	
560	Nov. 6, 2007	IBEW Negotiations	X	
560	Nov. 6, 2007	Specific employee matter - IT Director	X	
569	Jan 16, 2008	Specific employee matter - Administrator	X	
576	March 4, 2008	Specific employee matter - HR Manager	X	
578	March 11, 2008	FOP Negotiations	X	
583	April 8, 2008	Specific employee matter - HR Manager	X	
586	April 16, 2008	Specific employee matter - Administrator	X	
587	April 16, 2008	Specific employee matter - Administrator	X	
588	April 17, 2008	Specific employee matter - Administrator	X	
589	April 17, 2008	Specific employee matter - Administrator	X	
593	May 13, 2008	Specific employee matter - Administrator	X	
595	May 22, 2008	Specific employee matter - Administrator	X	
606	July 15, 2008	Specific employee matter - Administrator	X	
611	Aug. 12, 2008	Specific employee matter - Administrator	X	
617	Sept. 9, 2009	FOP Negotiations	X	
619	Oct. 7, 2008	FOP Negotiations	X	
625	Dec. 2, 2008	FOP Negotiations	X	

<u>Res #</u>	<u>Date</u>	<u>Subject</u>	<u>Confidentiality Still Exists</u>	<u>To Be Released</u>
657	Nov. 3, 2009	Specific employee matter - Fire Dept.	X	
657	Nov. 3, 2009	FOP Negotiations	X	
671	March 2, 2010	Specific employee matter - Police Dept.	X	
676	April 6, 2010	FOP Negotiations	X	
689	Aug. 17, 2010	FOP Negotiations	X	
689	Aug. 17, 2010	Specific employee mattter - HR Manager	X	
696	Oct. 12, 2010	FOP Negotiations	X	
700	Nov. 9, 2010	Specific employee matter - Fire Dept.	X	
700	Nov. 9, 2010	Pending litigation	X	
719	June 7, 2011	Collective Bargaining	X	
730	Sept. 6, 2011	Personnel	X	
749	May 1, 2012	FOP	X	
760	Oct. 10, 2012	IBEW & FOP Sgts.	X	
763	Nov. 6, 2012	FOP Negotiations	X	
763	Nov. 13, 2012	FOP Negotiations	X	
766	Jan. 8, 2013	Personnel	X	
766	Jan. 8, 2013	FOP Negotiations	X	
792	Jan. 7, 2014	Review of Closed Minutes	X	
794	Feb. 4, 2014	Litigation	X	
797	March 11, 2014	Personnel	X	
798	March 11, 2014	Personnel	X	
800	April 8, 2014	Personnel	X	
809	Aug. 5, 2014	Review of Closed Minutes	X	
812	Aug. 21, 2014	Personnel - Administrator Interview	X	
813	Aug. 21, 2014	Personnel - Administrator Interview	X	
7-15-1192	Dec. 1, 2015	Litigation	X	
7-15-1192	Dec. 21, 2015	Employment	X	
7-16-1212	April 26, 2016	FOP Negotiations	X	
7-17-1240	April 11, 2017	Purchase/Lease of Property	X	
7-17-1240	May 2, 2017	Purchase/Lease of Property	X	
7-17-1240	June 13, 2017	Personnel - need minutes	X	
1-18-1250	July 5, 2017	Review Closed Minutes	X	
1-18-1250	Aug. 24, 2017	Purchase/Sale of Property	X	

<u>Res #</u>	<u>Date</u>	<u>Subject</u>	<u>Confidentiality Still Exists</u>	<u>To Be Released</u>
1-18-1250	Aug. 24, 2017	Personnel	X	
1-18-1250	Sept. 5, 2017	IBEW Negotiations	X	
1-18-1250	Sept. 5, 2017	Personnel	X	
1-18-1250	Oct. 5, 2017	Personnel	X	
1-18-1250	Oct. 10, 2017	Personnel	X	
1-18-1250	Oct. 19, 2017	Personnel	X	
1-18-1250	Nov. 7, 2017	Sale or Lease of Property	X	
1-18-1250	Dec. 5, 2017	Sale or Lease of Property	X	
1-18-1250	Dec. 12, 2017	Sale or Lease of Property	X	
9-18-1262	Jan. 9, 2018	Sale or Lease of Property	X	
9-18-1262	Feb. 3, 2018	Review Closed Session Minutes	X	
9-18-1262	Feb.13, 2018	Board Self-evaluation	X	
9-18-1262	March 6, 2018	Sale or Lease of Property	X	
9-18-1262	March 27, 2018	Real Estate & Personnel	X	
9-18-1262	April 23, 2018	Board Self-evaluation	X	
9-18-1262	May 1, 2018	Real Estate	X	
9-18-1262	May 1, 2018	Litigation	X	
9-18-1262	May 1, 2018	Personnel	X	
1-19-1274	Aug. 1, 2018	Review Closed Session Minutes	X	
1-19-1274	Aug. 28, 2018	Personnel	X	
1-19-1274	Sept. 4, 2018	Sale of Property	X	
1-19-1274	Sept. 4, 2018	Personnel - Administrator	X	
1-19-1274	Sept. 11, 2018	Board Self-evaluation	X	
1-19-1274	Sept. 11, 2018	Personnel - Administrator	X	
1-19-1274	Oct. 2, 2018	Sale of Property	X	
1-19-1274	Oct. 2, 2018	Personnel - Administrator	X	
1-19-1274	Dec. 4, 2018	Sale of Property	X	
1-19-1274	Dec. 4, 2018	Legal Counsel	X	
7-20-1285	March 5, 2019	Sale or lease of property	X	
7-20-1285	March 5, 2019	Purchase or lease of property	X	
7-20-1285	April 2, 2019	FPO Negotiations	X	
7-20-1285	April 2, 2019	Purchase or lease of property	X	
7-20-1285	April 2, 2019	Sale or lease of property	X	
7-20-1285	April 2, 2019	Sale or lease of property	X	
7-20-1285	May 7, 2019	FOP Negotiations	X	
7-20-1285	May 7, 2019	Sale or lease of property	X	
7-20-1285	June 4, 2019	Sale or lease of property	X	
1-20-1299	July 9, 2019	Review of closed minutes	X	
1-20-1299	Aug. 13, 2019	Sale or lease of property	X	
1-20-1299	Aug. 13, 2019	FOP Negotiations	X	
1-20-1299	Dec. 3, 2019	Sale or lease of property	X	

<u>Res #</u>	<u>Date</u>	<u>Subject</u>	<u>Confidentiality Still Exists</u>	<u>To Be Released</u>
1-20-1299	Dec. 10, 2019	Sale or lease of property	X	
7-20-1307	Jan. 7, 2020	Review of closed minutes	X	
7-20-1307	June 9, 2020	Personnel	X	
1-21-1325	July 14, 2020	Review of closed minutes	X	
1-21-1325	Oct. 13, 2020	Personnel	X	
7-21-1342	Jan. 12, 2021	Personnel	X	
7-21-1342	Feb. 2, 2021	Sale or Lease of Property	X	
7-21-1342	Feb. 2, 2021	Personnel	X	
7-21-1342	Feb. 2, 2021	FOP Negotiations - Sgt.	X	
7-21-1342	Mach 2, 2021	Personnel	X	
7-21-1342	April 13, 2021	Personnel	X	
7-21-1342	June 1, 2021	Sale or Lease of Property	X	
2-22-1354	July 6, 2021	Review of Closed Minutes	X	
2-22-1354	Sept. 7, 2021	Sale or Lease of Property	X	
2-22-1354	Oct. 5, 2021	Sale or Lease of Property	X	
7-22-1361	Jan. 12, 2022	Review Closed Minutes	X	
7-22-1361	April 23, 2022	Self-evaluation, practies or procedures	X	
1-23-1379	July 5, 2022	Review of Closed Minutes	X	
1-23-1379	Oct. 4, 2022	IBEW Negotiations	X	
1-23-1379	Oct. 11, 2022	IBEW Negotiations	X	
1-23-1379	Nov. 1 2022	IBEW Negotiations	X	
1-23-1379	Nov. 2022	Personnel	X	
7-23-1393	Jan. 3, 2023	Review Closed Minutes	X	
7-23-1393	April 4, 2023	Personnel	X	
7-23-1393	April 4, 2023	FOP Contract	X	
7-23-1393	May 2, 2023	Personnel	X	
7-23-1393	May 2, 2023	Pending Litigation	X	
7-23-1393	May 2, 2023	FOP Contract	X	
7-23-1393	June 6, 2023	Purchase or Lease of Property	X	
1-24-1404	July 5, 2023	Review Closed Minutes	X	
1-24-1404	Aug. 1, 2023	Purchase or Lease of Property	X	
1-24-1404	Aug. 1, 2023	Sale or Lease of Property	X	
1-24-1404	Aug. 1, 2023	Litigation	X	
1-24-1404	Aug. 1, 2023	Personnel	X	
1-24-1404	Sept. 5, 2023	Purchase or Lease of Property	X	
1-24-1404	Sept. 5, 2023	Sale or Lease of Property	X	
1-24-1404	Oct. 10, 2023	Personnel	X	
1-24-1404	Nov. 7, 2023	Purchase or Lease of Property	X	
1-24-1404	Nov. 7, 2023	Sale or Lease of Property	X	

<u>Res #</u>	<u>Date</u>	<u>Subject</u>	<u>Confidentiality Still Exists</u>	<u>To Be Released</u>
1-24-1404	Nov. 7, 2023	Personnel	X	
1-24-1404	Dec. 5, 2023	Personnel	X	
7-24-1416	Jan. 9, 2024	Review of Closed Minutes	X	
7-24-1416	Jan. 9, 2024	Sale or Lease of Property	X	
7-24-1416	April 2, 2024	FOP Negotiations	X	
7-24-1416	April 2, 2024	Personnel	X	
7-24-1416	June 4, 2024	Personnel	X	
7-24-1416	June 4, 2024	Collective Negotiations	X	
7-24-1416	June 4, 2024	Litigation	X	
1-25-1426	July 9, 2024	Review of Closed Minutes	X	
1-25-1426	Sept. 10, 2024	Performance of employee	X	
1-25-1426	Sept. 10, 2024	Negotiations	X	
1-25-1426	Sept. 10, 2024	Purchase or lease of Property	X	
1-25-1426	Sept. 10, 2024	Setting Price for Property	X	
1-25-1426	Sept. 10, 2024	Litigation	X	
1-25-1426	Nov. 12, 2024	Personnel	X	
1-25-1426	Nov. 12, 2024	Sale or Lease of Property	X	
1-25-1426	Nov. 12, 2024	Litigation	X	
1-25-1426	Dec. 3, 2024	Sale or Lease of Property	X	
7-25-1439	Jan. 7, 2025	Review of Closed Minutes	X	
7-25-1439	Jan. 14, 2025	Litigation	X	
7-25-1439	March 4, 2025	Performance of employee	X	
7-25-1439	March 4, 2025	Sale or Lease of Property	X	
7-25-1439	March 4, 2025	Litigation	X	
7-25-1439	June 3, 2025	Purchase or lease of Property	X	
7-25-1439	June 10, 2025	Personnel	X	
1-26-1447	July 1, 2025	Review of Closed Minutes	X	
1-26-1447	Oct. 7, 2025	Personnel	X	
1-26-1447	Oct. 7, 2025	Collective Negotiations	X	
1-26-1447	Oct. 7, 2025	Litigation	X	
1-26-1447	Dec. 2, 2025	Personnel	X	
1-26-1447	Dec. 2, 2025	Collective Negotiations	X	
	Jan. 6, 2026	Employment		
	Jan. 6, 2026	Collective Negotiations		
	Jan. 6, 2026	Purchase or lease of Property		
	Jan. 6, 2026	Review Closed Minutes		
	March 3, 2026	Employment		
	March 3, 2026	Collective Negotiations		
	March 3, 2026	Sale of Property		
	March 10, 2026	Sale of Property		

<u>Res #</u>	<u>Date</u>	<u>Subject</u>	<u>Confidentiality Still Exists</u>	<u>To Be Released</u>
--------------	-------------	----------------	---	---------------------------

	April 7, 2026	Purchase or lease of Property		
	April 7, 2026	Litigation		
	April 7, 2026	Employment		
	May 5, 2026	Purchase or lease of Property		
	May 5, 2026	Employment		